



sartorius stedim  
biotech

## Microbiological Control



agopi  
LAB SOLUTIONS

[www.agapilabsolutions.com](http://www.agapilabsolutions.com)

turning science into solutions

**Contact Us:**  
Phone 1 (267) 397-3345  
E-mail [customerservice@agapilabsolutions.com](mailto:customerservice@agapilabsolutions.com)



# Table of Contents

<b>Air Monitoring</b>			
Air Sampler for Critical Applications	4	Combisart® – The Sterile-Vented Filter Station	38
AirPort MD8	5	Microsart® CombiJet	42
Gelatine Membrane Filters	6	How to Set-up a Vacuum Filtration System	44
BACTair™ – Big Impact	7	Traditional Multi-Branch Manifolds and Individual Filter Holders	47
Accessories	8	Accessories for Vacuum Filter Holders and Manifold Systems	50
		Electric Vacuum Pumps	52
<b>Colony Counting</b>		<b>Sterility Testing</b>	
Gridded Membrane Filters from Cellulose Nitrate (Cellulose Ester) acc. to ISO Standards	10	Sterility Testing Systems Sterisart® Universal Pump	60
Microsart® e.motion Dispenser	12	Sterility Testing Systems Sterisart® NF Reusable Sterility Test System	62
Microsart® e.motion Membrane Filters	13		66
Cellulose Nitrate (Cellulose Ester) Membrane Filters	14		
Cellulose Nitrate (Cellulose Ester) and Cellulose Acetate Membrane Filters	18		
Hydrophobic Edged Cellulose Nitrate (Cellulose Ester), Cellulose Acetate and Regenerated Cellulose Membrane Filters	20		
Nutrient Pad Sets	22		
Culture Media in Bottles and Tubes	26		
Biosart® 100 Monitors	28		
Biosart® 100 Nutrient Media	30		
Microsart® @filter 100			
Microsart® @filter 250	32		
Microsart® Funnel 100			
Microsart® Funnel 250	34		
Biosart® 250 Funnels	36		

## ► Air Sampler for Critical Applications



The system consists of the MD8 airscan® air sampler and disposable gelatine filter units. The system is routinely used for the quantitative detection of air-borne organisms, mainly at filling lines in sterile areas of class A (classification according to "EU Guide for GMP"), isolators, or blow-fill-seal machines.

The exceptionally high air flow rate of 8 m<sup>3</sup>/h enables isokinetic sampling at flow rates that are usual in laminar flow as well as filtration of 1 m<sup>3</sup> air very quickly (less than 8 minutes). The filter unit can be placed separately from the air sampler for remote sampling.

The MD8 airscan® air sampler allows to adjust selectively and easily air flow rate and sample removal speed. By means of a specially developed calibration unit (see accessories), the user can calibrate the MD8 airscan® locally, e.g. within the scope of validation steps.

After removing the sample, the gelatine filter can be placed directly on the agar culture medium for incubation and colony growth.

### ► Specifications

#### Specifications for the MD8 airscan® Air Sampler

Air flow rate	2.0 m <sup>3</sup> /h – 8 m <sup>3</sup> /h adjustable in 100-liter steps
Timer	1–99 minutes, adjustable in 1-minute steps
Max. deviation	±5% in a temperature range of 15°–35°C
Noise level	For gelatine membrane filters, max. 62 dB (A)
Weight	Approx. 6.5 kg
Dimensions (L×W×H)	375×242×228 mm
Correction of the air flow rate setting	When the entered air flow rate cannot be attained, the display shows the max. attainable flow rate for a corresponding new setting below this value.
Included filter holder	17655 (Gelatine disc filters)

#### Ordering Information for the MD8 airscan® Air Sampler

##### Order Number

16746	MD8 airscan® air sampler, 230 V, 50 Hz
16747	MD8 airscan® air sampler, 115 V, 60 Hz

Each version can be switched from 50 to 60 Hz and back.

#### Accessories for the MD8 airscan® Air Sampler

##### Order Number

17801	Holder for disposable gelatine filter units
-------	---

#### Ordering Information for Consumables

Disposable gelatine units, sterile, pack of 10

##### Order Number

17528--80---ACD	Individually packed in 1 polyethylene bag each
17528--80---BZD	Individually packed in 3 polyethylene bags each
17528--80---VPD	Individually packed in 3 polyethylene bags each, but label on innermost bag

Special brochures available on request. Order no. SMI2001-e | SM-3011-e

## ▶ AirPort MD8

### Battery-Powered Portable Air Sampler



AirPort MD8 is the air sampler for the pharmaceutical industry, the biotechnology, the food and beverage industry, for hospitals' environmental care and for work safety.

#### AirPort MD8 Offers the Following Benefits

- Battery-powered and portable for universal use.
- Battery power level clearly indicated so constant performance during sampling is guaranteed.
- Ergonomic design and easy to clean.

- Flexible adjustment possibilities of the volume flow and the sample volume.
- User-friendly prompting with the option of four languages; English, French, German and Spanish.
- Parameters last used stored even after automatic shut-off.
- The device can be calibrated locally.

For guaranteeing reliable and exact measurement results AirPort MD8 uses the gelatine membrane filter method or the impaction method with BACTair™.

### ▷ Specifications

#### Specifications for AirPort MD8

Volume flow regulation	By an integrated impeller wheel.
Volume flow adjustable	30 l/min., 40 l/min., 50 l/min. and 125 l/min.
Fixed given sample volumes	25, 50, 100, 250, 500, 750 and 1000 liters. In addition, the sample volume can be chosen manually in 5-liter steps.
Operational life with one battery charge	Approx. 4.5 hours for 50 l/min
Noise level	For gelatine membrane filters 48 dB (A)
Weight	Approx. 2.5 kg
Dimensions (L×W×H)	300×135×165 mm
Inclusive adapter	17801 (for disposable gelatine filter units) 17803 (for BACTair™ Plates)

#### Power Supply

Battery	NiMH 16.8 Volt/3800 mAh
Battery charger input	100–240 V/47–63 Hz/600 mA
Battery charger output	24 V/1000 mA
Charging time	Approx. 4.5 hours for empty battery

#### Ordering Information for the AirPort MD8

##### Order Number

16757	AirPort MD8, complete with two adapters (17801 and 17803) and battery charger (69898525).
-------	---

#### Accessories and Replacement Parts for the AirPort MD8

##### Order Number

17803	Adapter for BACTair™ on the AirPort MD8 air sampler
17801	Holder for disposable gelatine filter units
69898525	Battery charger

#### Ordering Information for Consumables

Please refer to the following pages.

Special brochures available on request. Order no. SM-1502-e and SM-4023-e

## ► Gelatine Membrane Filters

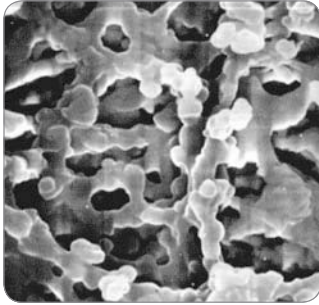

Gelatine filters in conjunction with the MD8 air samplers (gelatine filter method) are used for collecting of airborne microbes and viruses. Gelatine filter disposables are individually packed, pre-sterilized and ready-to-connect units, each consisting of a gelatine membrane filter and a holder. Gelatine membrane filters are still available as filter discs, suitable for the filter holder 17655 (80 mm diameter) supplied with the MD8 airscan® air samplers, as well as in smaller diameters.

Gelatine filters in conjunction with the MD8 air samplers offer the following features and benefits:

- "Absolute" retention rate (99.9995% for *Bac. sub. niger* spores, 99.94% for T3 phages).
- The filter maintains the viability of collected microorganisms for a relevant and meaningful sampling time.
- Gelatine filters are completely water-soluble. Therefore, microbes in one sample can be cultivated in | on different nutrient media or low and high bacteria counts can be measured. The sample is not affected by inhibitors.
- The solubility of the gelatine filter is a prerequisite for virus sampling.

### ► Specifications

#### Specifications of Gelatine Filters

Gelatine filters	Water soluble, pore size 3 µm, 80 mm diameter, thickness approx. 250 µm
Thermal resistance	Max. 60°C
Air flow rate	Approx. 2.7 l/min./cm <sup>2</sup> at ΔP = 0.05 bar
Retention rates	1. <i>Bac. subtilis niger</i> spores 99.9995% at 0.25 m/s inlet velocity. 2. Coli phages: phage T1, 99.9% at 0.3 m/s inlet velocity and 50% rel. air humidity. Phage T3, 99.94% at 0.3 m/s inlet velocity and 80% rel. humidity.
Filtration area	38.5 cm <sup>2</sup>
Conditions for use	Room temperature, max. 30°C, max. air humidity 85%
Sterilization	Supplied pre-sterilized by gamma irradiation

#### Disposable Gelatine Units, Sterile, Pack of 10

##### Order Number

17528--80---ACD	Individually packed in 1 polyethylene bag each
17528--80---BZD	Individually packed in 3 polyethylene bags each
17528--80---VPD	Individually packed in 3 polyethylene bags each, but label on innermost bag

#### Gelatine Disc Filter, Sterile, Sealed in Units of Five Each in a Polyethylene Bag

Order Number	Diameter	Package Size
12602--80---ALK	80 mm	50
12602--50---ALN	50 mm	100
12602--50---ALK	50 mm	50
12602--47---ALN	47 mm	100
12602--47---ALK	47 mm	50
12602--37---ALK	37 mm	50

Special brochure available on request. Order no. SM-3011-e

## ▶ BACTair™ – Big Impact

Microbiological Air Monitoring by the Impaction Method



A new developed system for sampling airborne organisms that allows impaction onto culture media plates, where the plates function directly as collection heads. This means that the collection properties are integrated right into the culture media plates. Metal sieve plates or metal collection heads with slots, which have to be sterilized for routine samplings on a regular basis, are eliminated. Now, non-sterile sieves or slots have become a thing of the past.

The geometry of the culture medium plate and the 400 holes in the sieve plate yield exceptional sampling efficiency, which is generally higher than that of other impaction samplers.

This new method uses the AirPort MD8 air sampler to draw the air stream over the BACTair™ Culture Media Plates. BACTair™ is ready-to-connect to the AirPort MD8.

BACTair™ offers the following benefits

- Individually, sterile packaged
- Integrated disposable sieve
- Pre-filled with agar media
- Samples 1 m<sup>3</sup> in just 8 min
- Optimized geometry

### ▷ Specifications

#### Specifications for BACTair™

Material	Polystyrene
Dimensions	116×24 mm
Number of impaction holes	400 holes, Ø 0.47 mm each
High retention of particles	> 0.65 µm
Sterilization	Gamma irradiation

#### BACTair™ Culture Media Plates with Agar, 110 mm, Individually, Sterile Packaged, 10 Units

Order Number	Determination of	Medium Type
14320-110----ACD	Total Count	Tryptic Soy Agar (TSA)
14321-110----ACD	Yeasts and molds	Sabouraud Agar (acc. USP)

#### Air Sampler

16757	AirPort MD8 Air Sampler for BACTair™ incl. charger
-------	--

#### Accessories

17803	Adapter for BACTair™ on the AirPort MD8 air sampler
1ZPX-D0002	Covers for BACTair™ Culture Media Plates, 10×2 units individually, sterile packaged
14301-110-----K	BACTair™ Plates, sterile, without media, 50 units

Special brochures are available on request. Order no. SM-4023-e and SL-2047-e

## ► Accessories

For the MD8 Air Samplers



### Calibration Unit

The user can calibrate the MD8 airscan® and AirPort MD8 directly on the job by means of the calibration unit\*.

This is absolutely necessary above all within the scope of validation steps, for which it is important that the shown air flow rate (desired value at the MD8) corresponds to the actual air amount (actual value at the calibration device). The calibration unit is supplied complete with battery charger | power supply unit (specific for the country in which it is used), filter holder, connectors set and connection tube (PVC, 2 m).

\* Alternatively, a maintenance agreement can be signed. Within the scope of the contractual services, Sartorius Stedim Biotech technicians will carry out a calibration of the MD8 at regular intervals

## ► Specifications

### Specifications for Calibration Unit

Dimensions	Length, 300 mm (without filter holder), Width, 390 mm with handles Height, 182 mm min., 200 mm max. (adjustable feet)
Connectors	Quick locks (bayonet principle)
Operational life with full battery	Approx. 4 hours
Charge time for empty battery	Approx. 10 hours
Measuring range	1–16 m <sup>3</sup> /h
Max. error	1–16 m <sup>3</sup> /h, ±2%
Type of protection	IP 40
Allowable ambient temperature	Min. 0°C, max. 40°C
Weight	Approx. 11 kg

Special brochure available on request.  
Order no. SL-2028-e

### Tubing and Connectors Set

If the disposable gelatine filter unit is not placed directly at the MD8 airscan®, but at a distance from it, a flexible plastic hose (2 m or 5 m), a connectors set and, if not available, a holder (tripod 16970, double socket 16976, clamp 17037) are necessary for the connection between filter and MD8 airscan®. The autoclavable silicone hose is used instead of the flexible plastic hose, if the MD8 airscan® has to be used in sterile rooms, operating rooms, isolators, blow-fill-seal machines, etc. With this hose attached to the air outlet connector (exhaust), the waste air can be led off into another room.

### Case

A stable case for the transport and the storage of a MD8 airscan®, incl. accessories.

### Aluminum Stack

It consists of a middle part, 10 numbered filter holders and 2 end caps. The stack is first sterilized (by 180°C dry heat, 2 h), and then equipped with the filters under sterile conditions (LF cleanbench). The prepared filter holders are put on one side of the middle part. After removing the sample, the inserted filter holders are put on the other side of the middle part, so that used and unused filter holders are separated from each other.

### Accessories for Isolator Application

For the monitoring of isolators with MD8 airscan®, we recommend using stainless steel accessories such as adapters 17016 (DN25) or 17030 (DN30), clamps 17033 for sanitary flanges, connector 17659---001 or 17659---003 (for tri clamp) and the filter holder for gelatine filter disposables 17801---001 as well as a Sartofluor® capsule with PTFE membrane and sanitary flange inlet and outlet, for sterile air filtration inserted between the MD8 airscan® and isolator. This construction makes it possible that the MD8 air sampler remains outside the critical work area (the barrier function between different clean-room classes is maintained).



**Accessories for Remote Control Function**

Users of the MD8 airscan® now have the possibility of operating this air sampler from a distance, using either of two remote control configurations:

- Via a PC (with Microsoft 95/98 or higher) with MD8 airscan® dialog system and cable connection to the MD8 airscan® (1ZE---0004).
- Via a PLC interface unit (1ZE---0003).

**Gelatine Membrane Filter, 80 mm, Sterile, Pack of 50 for Use with Stack**

Gelatine membrane filters are still available as 80 mm filter discs, suitable for the filter holder supplied with the MD8 airscan®. The filters are sterile-supplied, but the filter holders have to be sterilized by dry heat (180°C, 2h) and then equipped with the filters under sterile conditions. For performing routine check-ups a stack is recommended.

**Further Consumables for Air Monitoring**

If gelatine filters cannot be used (high humidity, high temperature), it is recommended to use cellulose nitrate filters.

**Accessories for the MD8 Air Samplers****Order Numbers**

16756	Calibration unit for the MD8 air samplers
17208	Case for MD8 airscan®
17656	Aluminum stack for MD8 air samplers

**Replacement Parts for the Stack****Order Numbers**

17655	Individual filter holders for gelatine filter type 12602--80----ALK
17660	Middle part
17661	End cap

**Tubing and Connectors Set****Order Numbers**

17085	Flexible PVC hose with reinforced ends (2 m)
17088	Flexible PVC hose with reinforced ends (5 m)
17662	Silicone tubing, sterilizable (1 m, state length required)
17657	Set of connectors (consisting of 17658 and 17659), aluminum
17658	Connector (air sampler inlet to flexible hose), aluminum
17659	Connector (flexible hose to filter holder   adapter), aluminum

**Accessories for Isolator Application****Order Numbers**

17016	Adapter (DN 25 hose barb to 1"-1 1/2" sanitary flange) to connect MD8 airscan® to an isolator via silicone tubing and a filter capsule, stainless steel
17030	Adapter (DN 30 hose barb to 1"-1 1/2" sanitary flange) to connect MD8 airscan® to an isolator via flexible PVC hose and filter capsule, stainless steel
17033	Clamp for 1"-1 1/2" sanitary flanges, stainless steel
17659---001	Connector (flexible hose to filter holder   adapter), hose nipple, stainless steel
17659---003	Connector (flexible hose to filter holder   adapter), tri clamp, stainless steel
17801---001	Adapter for gelatine filter disposables, stainless steel
5185307TS-----SS	Sartofluor® MidiCap Capsule with PTFE membrane and sanitary flange inlet and outlet, for sterile air filtration inserted between the MD8 airscan® and isolator

**Accessories for Remote Control Function****Order Numbers**

1ZE---0003	Remote control (Interface) for MD8 airscan® designed for PLC units
1ZE---0004	Remote control for MD8 airscan® for use with PC (dialog system software)

**Consumables Used with Stack**

Gelatine disc filters, 3 µm pore size, 80 mm, 50 pieces/pack

**Order Numbers**

12602-080 ALK	Gelatine disc filter, sterile, sealed in units of five each in a polyethylene bag
---------------	---

**Further Consumables for Air Monitoring**

Cellulose nitrate membrane filters, 80 mm diameter, 100 pieces/pack

**Order Numbers**

11404--80----ALN	Cellulose nitrate membrane filters, 0.8 µm, white with black grid, pre-sterilized in bags of 5
13004--80----ALN	Cellulose nitrate membrane filters, 0.8 µm, gray with white grid, pre-sterilized in bags of 5
11301--80----ALN	Cellulose nitrate membrane filters, 8 µm, white no grid, pre-sterilized in bags of 5

## ▶ Gridded Membrane Filters from Cellulose Nitrate (Cellulose Ester) acc. to ISO Standards

Sterile and Individually Packaged, for Colony Counting



Sterile, individually packed filters have long become standard for routine microbiological quality control because of the user benefits they offer.

They are pre-sterilized and ready-to-use and save preparatory time. As they are individually packed, they avoid the possibility of contamination of remaining filters in opened packs and conform with GLP, having filter identification and lot number printed on each individual envelope.

The increasing demand on these filters required the construction of a new packaging machine with ultra-modern stamping. Each membrane is checked to ensure it is not damaged in any way, is positioned correctly with no slippage under the edge seal, has perfect grid printing and is free of particles. Each envelope is checked for readable lettering. Quality control par excellence!

These membrane filters are in accordance with the following norms: ISO 7704, ISO 7899-2, ISO 8199, ISO 9308-1 and ISO 16266. In addition to this they have been manufactured for use especially at the same time with Sartorius Stedim Biotech Nutrient Pads in accordance with the AFNOR (French Standards), the American Petroleum Institute, the American Society for Microbiology, the APHA Standard Methods, the Association of Official Analytical Chemists, the British Drinking Water Guideline, the British Standards, the DGHM (German Association of Hygiene and Microbiology), the DIN Guidelines (German Standards), the European Brewery Community, the European Drinking Water Guideline 98/83, the European Pharmacopoeia, the German Pharmacopoeia, the International Commission for Uniform Methods of Sugar Analysis, the International Dairy Federation, the International Fruit Juice Producers, the ISO Guidelines, the LMBG (German food law), the method described by Lanaridris & Lafon-Lafourcade, the method described in the journal of Food Protection, the method described in the journal of the Institute of Brewing, the methods of the Central European Brewery Commission, the MNO (Mineral|Table Water Guideline), the National Canners Association, the testing procedures for packaging stuff, the U.S. Environmental Protection Agency, the United States Pharmacopoeia, the US Department of Agriculture, the VLB (German Institute of Brewery), the Zentralblatt für Hygiene (Journal of Hygiene), the US Federal Drug Administration and Internal Standard Operation Procedures.

## ▷ Specifications

### **The Membrane Filters**

All membranes are made of cellulose nitrate, a material which assures effective retention with high flow rates and optimum colony growth. The printed grid with a size of  $3.1 \times 3.1$  mm makes the counting easier, especially for higher bacteria counts and for microcolonies, but does not influence the growth. The various filter colors allow the best contrast to the colonies and particles.

### **High Flow Membranes**

The standard membrane filter for microbiological analysis is an  $0.45 \mu\text{m}$  filter. One special variant is the High Flow membrane. It provides 30% higher flow rates in comparison to traditional  $0.45 \mu\text{m}$  membranes. The special pore structure of the new  $0.45 \mu\text{m}$  HighFlow membrane filters allows shorter filtration times due to higher flow rates and throughputs. Especially *E. coli* shows best growth promotion on High Flow Membranes. As every Sartorius Stedim Biotech  $0.45 \mu\text{m}$  membrane filter lot, these membranes are also tested and released according to ISO 7704.

### **Additional Membrane Filters**

Cellulose nitrate (cellulose ester) membrane filters, gridded, non-sterile packaged (page 16).

Cellulose nitrate (cellulose ester) and cellulose acetate membrane filters, white, individually, sterile packaged (page 18).

Hydrophobic edge membranes are used mainly in the sterility testing of solutions containing antibiotics (page 20).

## ► Microsart® e.motion Dispenser



Fully automated membrane filter dispenser for individually sterile cellulose nitrate filter discs.

The membrane filters are automatically removed from their sterile package – either in a touch-free mode via an optical sensor or at the touch of a button. A pedal switch can be optionally connected to the dispenser. Thanks to their motorized traction roller, each filter is quickly and reliably dispensed. Membranes that accidentally slide out of their packaging or that even get damaged in the process are now problems of the past.

The controller specially developed for the Microsart® e.motion prevents unwanted dispensing of several membrane filters at a time – it's simple, "fail-safe," and fast.

The clear, compact design of the dispenser allows quick and easy cleaning. The Microsart® e.motion has an interface port available so that other sensor systems can be connected to control the dispenser.

The dispenser's low weight makes it easy to transport. Both its functions and design are ideal, giving you the versatility and flexibility you need in your lab.

### Applications

Membrane filters for colony counting, particle testing and microscopy

Some of the advantages you will benefit from when using the Microsart® e.motion dispenser:

- Fully automated membrane filter dispenser
- Works hands-free by an optical sensor
- Works by touch button
- Compact design
- Rapid and reliable transport due to sprocket feed roll technology
- Easy insertion of the filter band
- Easy-to-clean

## ► Specifications

### Specifications of the Microsart® e.motion Dispenser

Dimensions (L×H×W) in mm	204×213×165
Weight	2.9 kg
Operating voltage	110 V/230 V optional
Frequency	50–60 Hz
Max. power	Consumption 10 W
Dispensing speed	0.5 sec
Dispenser delay	5 sec
Certificates	CE Mark and EMC Directive, European Standards EN 50081-1 and -2, EN 50082-1 and -2, EN 61010

### Order Number for Microsart® e.motion Dispenser

16712	Microsart® e.motion dispenser, fully automated membrane filter dispenser.
1ZE---0028	Foot switch for Microsart® e.motion dispenser

## ► Microsart® e.motion Membrane Filters



The membrane filter band specially designed for the Microsart® e.motion can be conveniently inserted, and changed easily and rapidly as needed, even without having to completely use up a complete package quantity. Each box contains 100 membrane filters individually sealed on a special pleated band, and is designed so that it is easy to open and seal for storage. Microsart® e.motion – reliable help in your lab.

Some of the advantages you will benefit from when using the Microsart® e.motion membrane filters:

- Outstanding recovery rates for microorganisms
- 0.45 µm are acc. to ISO 7704
- Multi-fit: Fits into various dispensers
- Protective paper-free
- Packaged on a special pleated band
- Product data are printed on
- High Flow membranes available
- Gamma irradiated, 25kGray

### ► Specifications

Please refer to the membrane type:  
Cellulose nitrate (cellulose ester), gridded, individually, sterile packaged.

**Order Numbers for Microsart® e.motion Membrane Filters**  
**Diameter 47 mm or 50 mm, in Pack of 3 × 100 Membranes, Individually, Sterile Packaged, Without Protective Paper**

White   black	11407Z-47----SCM	0.2 µm
White   black	11407Z-50----SCM	0.2 µm
White   black	114H6Z-47----SCM	0.45 µm High Flow
White   black	114H6Z-50----SCM	0.45 µm High Flow
White   black	11406Z-47----SCM	0.45 µm
White   black	11406Z-50----SCM	0.45 µm
White   black	11404Z-47----SCM	0.8 µm
White   black	11403Z-47----SCM	1.2 µm
White   black	11403Z-50----SCM	1.2 µm
White   black	11402Z-47----SCM	3 µm
White   green	139H6Z-47----SCM	0.45 µm High Flow
White   green	13906Z-47----SCM	0.45 µm
White   green	13906Z-50----SCM	0.45 µm
Green   dark green	13806Z-47----SCM	0.45 µm
Green   dark green	13806Z-50----SCM	0.45 µm
Gray*   white	130H6Z-50----SCM	0.45 µm High Flow
Gray*   white	13006Z-47----SCM	0.45 µm
Gray*   white	13006Z-50----SCM	0.45 µm
Gray*   white	13005Z-47----SCM	0.65 µm
Gray*   white	13005Z-50----SCM	0.65 µm
Gray*   white	13004Z-47----SCM	0.8 µm
Gray*   white	13004Z-50----SCM	0.8 µm

\* Gray membranes after wetting black

Microsart® e.motion Membrane Filters are also available together with Nutrient Pads (page 23).

## ▶ Cellulose Nitrate (Cellulose Ester) Membrane Filters

Gridded, Individually, Sterile Packaged

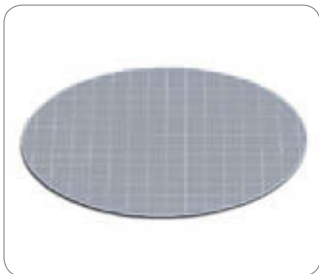
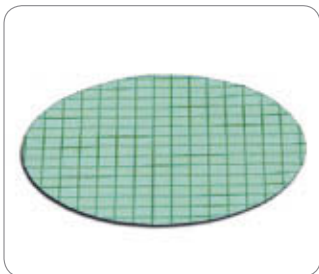
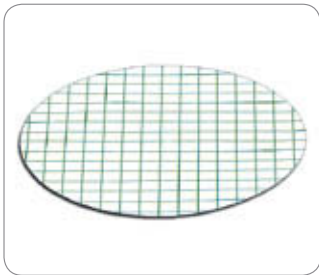

### Applications

Membrane filters for colony counting, particle testing and microscopy

Some of the advantages you will benefit from when using this type of membrane filter:

- Outstanding recovery rates for microorganisms
- 0.45 µm are acc. to ISO 7704
- High Flow membranes available
- Three different colors available
- Certified quality
- Gamma irradiated, 25kGray

### ▷ Specifications

Design	47 or 50 mm in diameter, white, grey or green and gridded
Growth Promotion Test acc. to ISO 7704	<ul style="list-style-type: none"> <li>- No enhancement or inhibition by the grid lines</li> <li>- No enhancement or inhibition due to chemical extractables</li> <li>- No enhancement or inhibition by the sterilization process</li> </ul>
Sterility test	Sterile
Thermal resistance	130°C max.
Thickness acc. to DIN 53105	115–145 µm
Chemical compatibility	Aqueous solutions (pH 4–8), hydrocarbons and several other organic solvents. Detailed information in section "Chemical Compatibility" under Cellulose Nitrate type 113 (page 770).

### Typical Performance Rates for Various Pore Sizes

Pore size		0.2 µm*	0.45 µm**	0.45 µm High Flow**	0.65 µm
Flow rate for water per cm <sup>2</sup> at 1 bar acc. to DIN 58355	in ml/min	20	70	100	130
Coliform retention	in %	100	100	100	n. a.
Recovery rate lot-released acc. to ISO 7704	in %	≥ 90	≥ 90	≥ 90	≥ 90

\*) Pore size determined by quantitative retention of *Brevundimonas diminuta* in accordance with the ASTM Document F 838-83 (1993) Standard test method for determining bacterial retention of membrane filters utilized for liquid filtration.

\*\*) Pore size determined by quantitative retention of *Serratia marcescens* in accordance with the Standard Methods of Water and Waste Water

**White Membrane with Black Grid, for Detection of Bacteria with Dyed Media, Particle Count & Microscopy, Type 114, Individually, Sterile Packaged**

Pore Size	Order No.	Diameter	Pack Size
0.2 µm	11407--47----ACN	47 mm	100
	11407--47----ACR	47 mm	1,000
	11407--50----ACN	50 mm	100
	11407--50----ACR	50 mm	1,000
0.45 µm	11406--47----ACN	47 mm	100
	11406--47----ACR	47 mm	1,000
	11406--50----ACN	50 mm	100
	11406--50----ACR	50 mm	1,000
0.45 µm High Flow*	114H6--47----ACN	47 mm	100
	114H6--47----ACR	47 mm	1,000
	114H6--50----ACN	50 mm	100
	114H6--50----ACR	50 mm	1,000
0.65 µm	11405--47----ACN	47 mm	100
	11405--50----ACN	50 mm	100
0.8 µm	11404--47----ACN	47 mm	100
	11404--47----ACR	47 mm	1,000
	11404--50----ACN	50 mm	100
1.2 µm	11403--47----ACN	47 mm	100
	11403--47----ACR	47 mm	1,000
	11403--50----ACN	50 mm	100
	11403--50----ACR	50 mm	1,000

**White Membrane with Green Grid, for Detection of Bacteria with Dyed Media, Particle Count and Microscopy, Type 139, Individually, Sterile Packaged**

0.45 µm	13906--47----ACN	47 mm	100
	13906--47----ACR	47 mm	1,000
	13906--50----ACN	50 mm	100
	13906--50----ACR	50 mm	1,000
0.45 µm High Flow*	139H6--47----ACN	47 mm	100
	139H6--47----ACR	47 mm	1,000
	139H6--50----ACN	50 mm	100
0.65 µm	13905--47----ACN	47 mm	100
1.2 µm	13903--47----ACN	47 mm	100

**Green Membrane with Dark-Green Grid, Providing Optimal Contrast to Light-Colored or Transparent Bacteria Colonies, Type 138, Individually, Sterile Packaged**

0.45 µm	13806--47----ACN	47 mm	100
	13806--47----ACR	47 mm	1,000
	13806--50----ACN	50 mm	100
	13806--50----ACR	50 mm	1,000

**Gray Membrane (After Wetting, Black) with White Grid, for Detection of Yeasts and Molds, Particle Count and Microscopy, Type 130, Individually, Sterile Packaged**

0.45 µm	13006--47----ACN	47 mm	100
	13006--47----ACR	47 mm	1,000
	13006--50----ACN	50 mm	100
	13006--50----ACR	50 mm	1,000
0.65 µm	13005--47----ACN	47 mm	100
	13005--50----ACN	50 mm	100
	13005--50----ACR	50 mm	1,000
0.8 µm	13004--47----ACN	47 mm	100
	13004--47----ACR	47 mm	1,000
	13004--50----ACN	50 mm	100

## ▶ Cellulose Nitrate (Cellulose Ester) Membrane Filters

Gridded, Non-Sterile Packaged

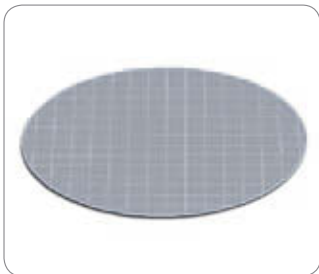
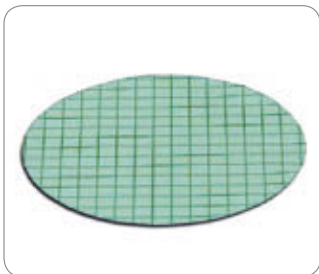
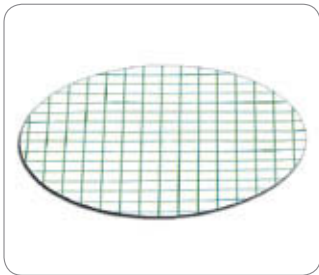
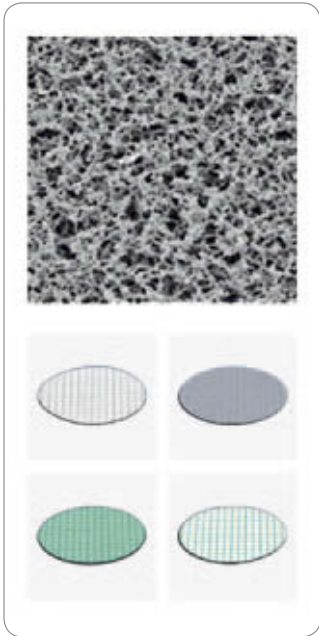

**Applications**  
Membrane filters for colony counting, particle testing and microscopy

Some of the advantages you will benefit from when using this type of membrane filter:

- Outstanding recovery rates for microorganisms
- 0.45 µm are acc. to ISO 7704
- Three different colors available

### ▷ Specifications

Design	25, 47 or 50 mm in diameter, white, grey or green and gridded
Growth Promotion Test acc. to ISO 7704	- No enhancement or inhibition by the grid lines - No enhancement or inhibition due to chemical extractables
Thermal resistance	130°C max.
Thickness acc. to DIN 53105	115–145 µm
Chemical compatibility	Aqueous solutions (pH 4–8), hydrocarbons and several other organic solvents. Detailed information in section "Chemical Compatibility" under Cellulose Nitrate type 113 (page 770).

### Typical Performance Rates for Various Pore Sizes

Pore size		0.2 µm*	0.45 µm**	0.65 µm
Flow rate for water per cm <sup>2</sup> at 1 bar acc. to DIN 58355	in ml/min	20	70	130
Coliform retention	in %	100	100	n. a.
Recovery rate lot-released acc. to ISO 7704	in %	≥ 90	≥ 90	≥ 90

\* ) Pore size determined by quantitative retention of *Brevundimonas diminuta* in accordance with the ASTM Document F 838-83 (1993) Standard test method for determining bacterial retention of membrane filters utilized for liquid filtration.

\*\* ) Pore size determined by quantitative retention of *Serratia marcescens* in accordance with the Standard Methods of Water and Waste Water



**White Membrane with Black Grid, for Detection of Bacteria with Dyed Media, Particle Count & Microscopy, Type 114, Non-Sterile**

Pore Size	Order No.	Diameter	Pack Size
0.2 µm	11407--25-----N	25 mm	100
	11407--47-----N	47 mm	100
	11407--47-----R	47 mm	1,000
	11407--50-----N	50 mm	100
0.45 µm	11406--25-----N	25 mm	100
	11406--47-----N	47 mm	100
	11406--47-----R	47 mm	1,000
	11406--50-----N	50 mm	100
	11406--50-----R	50 mm	1,000
0.65 µm	11405--47-----N	47 mm	100
0.8 µm	11404--25-----N	25 mm	100
	11404--47-----N	47 mm	100
	11404--50-----N	50 mm	100
1.2 µm	11403--25-----N	25 mm	100
	11403--47-----N	47 mm	100
	11403--50-----N	50 mm	100

**White Membrane with Green Grid, for Detection of Bacteria with Dyed Media, Particle Count and Microscopy, Type 139, Non-Sterile**

0.45 µm	13906--47-----N	47 mm	100
	13906--47-----R	47 mm	1,000
	13906--50-----N	50 mm	100
	13906--50-----R	50 mm	1,000

**Green Membrane with Dark-Green Grid, Providing Optimal Contrast to Light-Colored or Transparent Bacteria Colonies, Type 138, Non-Sterile**

0.45 µm	13806--47-----N	47 mm	100
	13806--47-----R	47 mm	1,000
	13806--50-----N	50 mm	100
	13806--50-----R	50 mm	1,000

**Gray Membrane (After Wetting, Black) with White Grid, for Detection of Yeasts and Molds, Particle Count and Microscopy, Type 130, Non-Sterile**

0.45 µm	13006--25-----N	25 mm	100
	13006--47-----N	47 mm	100
	13006--47-----R	47 mm	1,000
	13006--50-----N	50 mm	100
0.65 µm	13005--47-----N	47 mm	100
	13005--50-----N	50 mm	100
0.8 µm	13004--47-----N	47 mm	100
	13004--50-----N	50 mm	100

## ▶ Cellulose Nitrate (Cellulose Ester) and Cellulose Acetate Membrane Filters

White, Individually, Sterile Packaged



Sterile, individually packed filters have long become standard for routine microbiological quality control because of the user benefits they offer. They are pre-sterilized and ready-to-use and save preparatory time. As they are individually packed, they avoid the possibility of contaminating remaining filters in opened packs and conform with GLP, having filter identification and lot number printed on each individual envelope.

### Materials

The membranes are made of even cellulose nitrate (cellulose ester), a material which assures effective retention with high flow rates and optimum colony growth or cellulose acetate, a material which combines high flow rates and thermal stability with very low adsorption characteristics.

### Additional Applications

11301, a white CN membrane filter with a pore size of 8  $\mu\text{m}$  is used as a prefilter in a special prefilter attachment (16807) for bacteriological analyses. It retains the coarse suspended particles, whereas it allows microorganisms to pass through. These microbes are trapped on the surface of the underlying bacteria-retentive membrane filter (e. g. 0.45  $\mu\text{m}$ ).

11107, a white CA membrane filter with a pore size of 0.2  $\mu\text{m}$  is the filter of choice for sterile filtration, such as nutrient media, buffer and sera. This membrane is validated by the Bacteria Challenge Test.

### Applications

Membrane filters for colony counting, sterility testing, particle testing and microscopy

Some of the advantages you will benefit from when using this type of membrane filter:

- Outstanding recovery rates for microorganisms
- Defined particle retention
- 0.45  $\mu\text{m}$  are acc. to ISO 7704
- 0.2  $\mu\text{m}$  are validated by BCT
- Certified quality
- Gamma-irradiated, 25kGray

### ▷ Specifications

Design	25, 47 or 50 mm in diameter, white
Growth Promotion Test acc. to ISO 7704	<ul style="list-style-type: none"> <li>- No enhancement or inhibition by the sterilization process</li> <li>- No enhancement or inhibition due to chemical extractables</li> </ul>
Sterility test	Sterile
Thermal resistance	CN: 130°C max.   CA: 180°C max.
Thickness acc. to DIN 53105	CN: 115–145 µm   CA: 120 µm (average value)
Chemical compatibility	Aqueous solutions (pH 4–8), hydrocarbons and several other organic solvents. Detailed information in section "Chemical Compatibility" under Cellulose Nitrate type 113 and Cellulose Acetate type 111 (page 770).

#### **Cellulose Nitrate Membrane Filters, White, for Colony Counting, Sterility Testing, Particle Count & Microscopy, Type 113, Individually, Sterile Packaged**

Pore Size	Order No.	Diameter	Pack Size
0.45 µm	11306--25----ACN	25 mm	100
	11306--47----ACN	47 mm	100
	11306--50----ACN	50 mm	100
0.65 µm	11305--47----ACN	47 mm	100
	11305--50----ACN	50 mm	100
0.8 µm	11304--47----ACN	47 mm	100
	11304--50----ACN	50 mm	100
1.2 µm	11303--47----ACN	47 mm	100
	11303--50----ACN	50 mm	100
3 µm	11302--47----ACN	47 mm	100
	11302--50----ACN	50 mm	100
8 µm	11301--47----ACN	47 mm	100
	11301--50----ACN	50 mm	100

#### **Cellulose Acetate\* Membrane Filters, White, for Colony Counting, Sterility Testing, Particle Count & Microscopy, Type 111, Individually, Sterile Packaged**

0.2 µm	11107--47----ACN	47 mm	100
	11107--50----ACN	50 mm	100
0.45 µm	11106--47----ACN	47 mm	100
	11106--50----ACN	50 mm	100

\* If cellulose nitrate is not compatible

## ▶ Hydrophobic Edged Cellulose Nitrate (Cellulose Ester), Cellulose Acetate and Regenerated Cellulose Membrane Filters

Individually, Sterile Packaged & Non-Sterile



Hydrophobic edge membranes are used mainly for colony counting and sterility testing of solutions containing substances with antibiotic characteristics. The hydrophobic edge avoids the penetration of any growth-inhibitory substance into the membrane clamp zone wherefrom it could not be rinsed out and the substance could inhibit microbial growth during incubation.

### Materials

The membranes are available in three different materials:

- Cellulose nitrate (cellulose ester), a material which assures effective retention with high flow rates and optimum colony growth
- Cellulose acetate, a material which combines high flow rates and thermal stability with very low adsorption characteristics
- Regenerated cellulose, a material which combines excellent chemical resistance and thermal stability with very low adsorption characteristics.

### Applications

Membrane filters for colony counting and sterility testing

Some of the advantages you will benefit from when using this type of membrane filter:

- Outstanding retention rates for microorganisms
- 0.45  $\mu\text{m}$  are acc. to ISO 7704
- 0.2  $\mu\text{m}$  are validated by BCT
- Certified quality

### ▷ Specifications

Design	25, 47 or 50 mm in diameter, white or white with black grid
Growth Promotion Test acc. to ISO 7704	<ul style="list-style-type: none"> <li>– No enhancement or inhibition by the grid lines</li> <li>– No enhancement or inhibition due to chemical extractables</li> <li>– No enhancement or inhibition by the sterilization process</li> </ul>
Sterility test	Sterile
Thermal resistance	CN: 130°C max.   CA and RC: 180°C max.
Thickness acc. to DIN 53105	CN: 115–145 $\mu\text{m}$   CA: 120 $\mu\text{m}$ (average value)   RC: 160–200 $\mu\text{m}$
Chemical compatibility	Aqueous solutions (pH 4–8), hydrocarbons and several other organic solvents, RC is resistant to almost all solvents and is compatible in a pH-range of 3–12. Detailed information in section "Chemical Compatibility" under Cellulose Nitrate type 113, page 770, Cellulose Acetate type 111 and Regenerated Cellulose type 184.

**Cellulose Nitrate Membrane Filters, White with Black Grid, 3 mm Hydrophobic Edge, for Colony Counting & Sterility Testing, Type 131, Individually, Sterile Packaged**

Pore Size	Order No.	Diameter	Pack Size
0.2 µm	13107--47----ACN	47 mm	100
	13107--50----ACN	50 mm	100
0.45 µm	13106--47----ACN	47 mm	100
	13106--50----ACN	50 mm	100

**Cellulose Nitrate Membrane Filters, White with Black Grid, 6 mm Hydrophobic Edge, for Colony Counting & Sterility Testing, Type 131, Individually, Sterile Packaged**

0.45 µm	13106--47----HEN	47 mm	100
---------	------------------	-------	-----

**Cellulose Nitrate Membrane Filters, White with Black Grid, 3 mm Hydrophobic Edge, for Colony Counting & Sterility Testing, Type 131, Non-Sterile**

0.2 µm	13107--25-----N	25 mm	100
	13107--47-----N	47 mm	100
	13107--50-----N	50 mm	100
0.45 µm	13106--25-----N	25 mm	100
	13106--47-----N	47 mm	100
	13106--50-----N	50 mm	100
8 µm	13101--47-----N	47 mm	100
	13101--50-----N	50 mm	100

**Cellulose Nitrate Membrane Filters, White, 3 mm Hydrophobic Edge, for Colony Counting & Sterility Testing, Type 131, Non-Sterile**

8 µm	13101--50----AHN	50 mm	100
------	------------------	-------	-----

**Cellulose Nitrate Membrane Filters, White with Black Grid, 6 mm Hydrophobic Edge, for Colony Counting & Sterility Testing, Type 131, Non-Sterile**

0.2 µm	13107--47----HCN	47 mm	100
0.45 µm	13106--47----HCN	47 mm	100

**Cellulose Acetate\* Membrane Filters, White with Black Grid, 3 mm Hydrophobic Edge, for Colony Counting & Sterility Testing, Type 135, Individually, Sterile Packaged**

0.2 µm	13507--47----ACN	47 mm	100
0.45 µm	13506--47----ACN	47 mm	100
	13506--50----ACN	50 mm	100

**Cellulose Acetate\* Membrane Filters, White with Black Grid, 3 mm Hydrophobic Edge, for Colony Counting & Sterility Testing, Type 135, Sterile, Packaged of 10 Discs per Sleeve**

0.45 µm	13506--47----ALS	47 mm	100
---------	------------------	-------	-----

**Cellulose Acetate\* Membrane Filters, White with Black Grid, 3 mm Hydrophobic Edge, for Colony Counting & Sterility Testing, Type 135, Non-Sterile**

0.2 µm	13507--47-----N	47 mm	100
0.45 µm	13506--47-----N	47 mm	100

**Cellulose Acetate\* Membrane Filters, White with Black Grid, 6 mm Hydrophobic Edge, for Colony Counting & Sterility Testing, Type 135, Non-Sterile**

0.45 µm	13506--47----HCN	47 mm	100
---------	------------------	-------	-----

**Regenerated Cellulose\* Membrane Filters, White, Hydrophobic Edged, for Colony Counting & Sterility Testing, Type 184, 100 Membranes per Box, Individually, Sterile Packaged**

0.45 µm	18406--47----ACN	47 mm	3 mm hydropho. edge
	18406--47----HDN	47 mm	4 mm hydropho. edge

\* If cellulose nitrate is not compatible

## ► Nutrient Pad Sets

Dehydrated Media Pads in Petri Dishes, with Matching Membrane Filters for Economical, Time-Saving Microbiological Quality Control

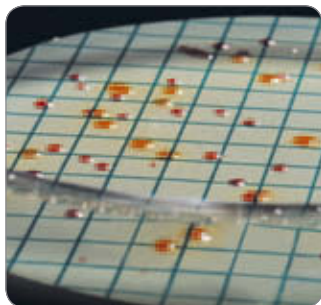

Sartorius Stedim Biotech Nutrient Pad Sets have been used successfully in the membrane filter method for 30 years. Practical and easy to handle, they reduce labor and simplify many microbiological testing procedures.

Nutrient pads are sterile, dehydrated culture media. Once they are moistened with 3.0–3.5 ml of sterile and demineralized (or distilled) water they are ready to use immediately.

### Ready-to-Use up to 24 Months

The standard NPS box contains 100 sterile nutrient pads, each of which is individually inserted in a petri dish and sterilized. Ten each of these petri dishes are sealed in an aluminum bag. This special packaging in bags protects the sensitive formula constituents of the nutrient pads during transport and storage from fluctuations in humidity and temperature. As a result, it guarantees the high quality of our NPS throughout their entire shelf life up to 24 months. This makes the Sartorius Stedim Biotech Nutrient Pads Sets unique: No other ready-to-use culture media around the globe assures such consistently high quality and reproducible results up to 24 months.

### Compliance with International Standards

Currently, Sartorius Stedim Biotech offers more than 30 different Nutrient Pad Set types to meet the diverse objectives of microbiological analysis. Aside from the European drinking water directive, they comply with other international regulations and recommendations: international pharmacopoeias, DIN and ISO standards, the American Standards for Water and Foods, mineral water regulations, brewery guidelines, such as MEBAC or EBC, and recommendations of the food industry, such as LMBG, NCA and ICUMSA, etc.

### Inclusive Membranes

All Nutrient Pad Set types are supplied with the appropriate membrane filters, which are also pre-sterilized and individually packaged. Microsart® e.motion Membrane Filters are specially designed for the Microsart® e.motion Dispenser and can be conveniently inserted. The membrane filters then are automatically removed from their sterile package – either in a touch-free mode via an optical sensor or at the touch of a button. All membrane filters tailored to meet the special requirements of microbial detection are available with 47 mm or 50 mm diameters.

### Benefits for the User

#### Economy

No time-consuming and labor-intensive preparation of the nutrient media (sterilization, cleaning, etc.).

#### Easy Handling

Nutrient Pad Sets can also be used in laboratories without comprehensive microbiological equipment.

#### Consistently Quality

During the production, each nutrient pad set batch is compared with the corresponding agar medium, in order to guarantee consistently quality and reproducible results.

#### Trouble-Free Storage

Nutrient Pad Sets can be stored at room temperature in a warehouse, up to 24 months.

**Order Numbers for Nutrient Pad Sets in Petri Dishes****Nutrient Pad Sets for Total Colony Counting,**

individually, sterile packaged in petri dishes, 100 per box, with 100 individually,  
sterile packaged 47 mm membrane filters (order no. -RDN = Microsart® e.motion Membranes)

Determination of	NPS Type (Filter Type) <sup>1</sup>	Order No. <sup>2</sup>
Total count	Caso (1)	14063--47-----N
Total count	R2A (1)	14084--47----RDN
Total count	R2A (1)	14084--47-----N
Total count	Standard TTC (1)	14055--47----RDN
Total count	Standard TTC (1)	14055--47-----N
Total count	Standard TTC I mod. (1)	14085--47-----N
Total count	Standard (1)	14064--47-----N
Total count	TGE   Tryptone Glucose Extract (1)	14076--47----RDN
Total count	TGE   Tryptone Glucose Extract (1)	14076--47-----N
Total count	Yeast Extract (1)	14090--47-----N

**Nutrient Pad Sets for E. coli, Coliforms and Enterobacteria,**

individually, sterile packaged in petri dishes, 100 per box, with 100 individually,  
sterile packaged 47 mm membrane filters (order no. -RDN = Microsart® e.motion Membranes)

E. coli and coliforms	Chromocult (7)	14087--47----RDN
E. coli and coliforms	Chromocult (7)	14087--47-----N
E. coli	ECD (2)	14082--47-----N
E. coli and coliforms	Endo (9)	14053--47----RDN
E. coli and coliforms	Endo (9)	14053--47-----N
Enterobacteria, E. coli	MacConkey (2)	14097--47-----N
E. coli and coliforms	m FC (2)	14068--47-----N
E. coli and coliforms	m FC in closed petri dishes (2)	14068--50----PDN
E. coli and coliforms	Teepol   Lauryl Sulphate (2)	14067--47----RDN
E. coli and coliforms	Teepol   Lauryl Sulphate (2)	14067--47-----N
E. coli and coliforms	Tergitol TTC (2)	14056--47----RDN
E. coli and coliforms	Tergitol TTC (2)	14056--47-----N

**Nutrient Pad Sets for Other Faecal Bacteria,**

individually, sterile packaged in petri dishes, 100 per box, with 100 individually,  
sterile packaged 47 mm membrane filters (order no. -RDN = Microsart® e.motion Membranes)

Enterococci	Azide   KF Strep (1)	14051--47----RDN
Enterococci	Azide   KF Strep (1)	14051--47-----N
Salmonellae	Bismuth Sulfite (1)	14057--47-----N

**Nutrient Pad Sets for Non-Faecal, Pathogenic Bacteria,**

individually, sterile packaged in petri dishes, 100 per box, with 100 individually,  
sterile packaged 47 mm membrane filters (order no. -RDN = Microsart® e.motion Membranes)

Pseudomonas aeruginosa	Cetrimide (2)	14075--47----RDN
Pseudomonas aeruginosa	Cetrimide (2)	14075--47-----N
Staphylococci, Staph. aureus	Chapman (2)	14074--47-----N

**Nutrient Pad Sets for Yeasts and Molds,**

individually, sterile packaged in petri dishes, 100 per box, with 100 individually, sterile packaged 47 mm membrane filters (order no. -RDN = Microsart® e.motion Membranes)

Determination of	NPS Type (Filter Type) <sup>1</sup>	Order No. <sup>2</sup>
Wild yeasts	Lysine (3)	14061--47-----N
Yeasts and molds	Malt Extract (8)	14086--47----CCN
Yeasts and molds	Malt Extract (6)	14086--47-----N
Yeasts and molds	Sabouraud (10)	14069--47-----N
Yeasts and molds	Schaufus Pottinger   m green yeast and mold (4)	14070--47-----N
Yeasts and molds	Schaufus Pottinger   m green yeast and mold (5)	14072--47-----N
Yeasts and molds	Schaufus Pottinger   m green yeast and mold (6)	14080--47----RDN
Yeasts and molds	Schaufus Pottinger   m green yeast and mold (6)	14080--47-----N
Yeasts and molds	Schaufus Pottinger   m green yeast and mold (3)	14083--47-----N
Yeasts and molds	Schaufus Pottinger   m green yeast and mold (8)	14091--47----RDN
Yeasts and molds	Schaufus Pottinger   m green yeast and mold (8)	14091--47-----N
Yeasts and molds and bacteria	Wallerstein Nutrient   WL Nutrient (2)	14089--47-----N
Yeasts and molds	Wort (3)	14058--47----RDN
Yeasts and molds	Wort (3)	14058--47-----N
Yeasts and molds	Wort (8)	14092--47----RDN

**Nutrient Pad Sets for Product-Spoiling Microorganisms,**

individually, sterile packaged in petri dishes, 100 per box, with 100 individually, sterile packaged 47 mm membrane filters (order no. -RDN = Microsart® e.motion Membranes)

Thermophilic spore formers and mesophilic bacteria	Glucose Tryptone (2)	14066--47-----N
Leuconostoc oenos and other wine-spoiling organ.	Jus de Tomate   Tomato Juice (1)	14079--47-----N
Lactobacilli and other soft drink-spoiling microorganisms	MRS (1)	14077--47-----N
Acid-tolerant microorganisms	Orange Serum   pH 5.5 (1)	14062--47----RDN
Acid-tolerant microorganisms	Orange Serum   pH 5.5 (1)	14062--47-----N
Acid-tolerant microorganisms	Orange Serum   pH 3.2 (6)	14096--47----RDN
Acid-tolerant microorganisms	Orange Serum   pH 3.2 (6)	14096--47-----N
Lactobacilli and Pediococci and other beer-spoiling microorganisms	VLB-S7-S (2)	14059--47-----N
Mesophilic slime-forming bacteria esp. Leu. mesenteroides	Weman (1)	14065--47-----N



## Nutrient Pad Sets Starter Kit,

individually, sterile packaged in petri dishes, 100 per box, with 100 individually, sterile packaged 47 mm membrane filters

E. coli and coliforms, total count, yeasts and molds, Mixed types: Endo, Standard, Wort (1, 2, 3) 14095--47-----N

Special brochure available on request f.o.c. Order no. SM-4017-e.

- 1) The membrane filters are selected for optimum growth, together with the corresponding nutrient media. The supplied membrane filter type is listed within brackets:
  - (1) = Green with dark-green grid, 0.45 µm pore size
  - (2) = White with green grid, 0.45 µm pore size
  - (3) = Gray (after wetting black) with white grid, 0.65 µm pore size
  - (4) = White with green grid, 0.65 µm pore size
  - (5) = White with green grid, 1.2 µm pore size
  - (6) = Gray (after wetting black) with white grid, 0.8 µm pore size
  - (7) = White with black grid, 0.45 µm pore size
  - (8) = Gray (after wetting black) with white grid, 0.45 µm pore size
  - (9) = White with green grid, 0.45 µm pore size, High Flow (ideal for E.coli)
  - (10) = Gray (after wetting black) with white grid, 0.45 µm pore size, High Flow
- 2) Diameter of the membrane filter, 47 mm. Order number for Nutrient Pad Set with 50 mm membrane filter as above, but --47-----N replaced by --50-----N.  
Most of the NPS types are also available with Microsart® e.motion Membrane Filters: Order number as above, but ---N replaced by -RDN.

Other NPS types and NPS with Microsart® e.motion Membrane Filters on request.

### Nutrient Pad Sets

turning science into solutions

**sartorius stedim**  
biotech

Total applications examples

Medium	Application	Microsart® e.motion Membrane Filter
Endo	Endo	Endo
Standard	Standard	Standard
Wort	Wort	Wort
...	...	...

© 2015 Sartorius Stedim Biotech. All rights reserved. The information provided in this document is for informational purposes only and does not constitute a contract. The information is subject to change without notice. For more information, please contact your local Sartorius Stedim Biotech representative.

## Nutrient Pad Set Poster

The photo shows a poster, original size 70 cm x 50 cm, with growth patterns and typical applications for the Nutrient Pad Sets, described on the previous page. On request, you can obtain this poster free of charge. Order no. SM-0001-e.

## ► Culture Media in Bottles and Tubes

### Absorbent Pads and Petri Dishes



#### Agar Media

The traditional culture media for microorganisms is agar media. This can be used for the membrane filtration method or for direct incubation. There are two different forms available: Agar media in tubes are for pouring agar plates. The content of one tube is sufficient for two 90 mm or three 60 mm petri dishes. Agar media in bottles are the cost-effective alternative for casting plates.

#### Liquid Broth Media

Liquid culture media broth for direct incubation or for wetting an absorbent pad before a membrane filter is placed on it. They are available in tubes and in bottles.

#### Absorbent Pads

Sartorius Stedim Biotech 1.4 mm thick absorbent pads are wetted with the appropriate liquid culture medium before a membrane filter is placed on them. They come pre-sterilized in plastic magazines, which fit onto the Sartorius Stedim Biotech manual dispensing device. The absorbent pads are available in two diameters:

- 47 mm with approx. 3 ml absorption capacity and
- 50 mm with approx. 3.5 ml absorption capacity.



#### Agar Media in 250 ml Bottles, 4 Bottles per Box

Determination of	Agar Type	Order No.
Total count	Nutrient	14144-----A
Yeasts and molds	Wort	14157-----A
Wild yeasts	Lysine	14143-----A
Lactobacilli and Pediococci and other beer-spoiling organisms	VLB-S7-S	14148-----A



#### Agar Media in 20 ml Tubes, 50 Tubes per Box

Determination of	Agar Type	Order No.
Total count	Nutrient	14137-----K
Total count	Standard	14131-----K
Yeasts and molds	Wort	14138-----K
Acid-tolerant microorganisms	Orange serum	14130-----K
Leuconostoc oenos and other wine-spoiling organ.	Jus de tomate (tomato juice)	14140-----K



#### Lactose Broth Media, Bottled Concentrate, for Drinking Water Analysis

Concentration Factor	Packaging	Order No.
Two times concentrated	4 bottles à 100 ml	14155-----A

**Broth Media in 20 ml Tubes, 50 Tubes per Box**

Determination of	Broth Type	Order No.
Lactobacilli and Pediococci and other beer-spoiling organisms	VLB-S7-S	14127-----K

**Absorbent Pads, 47 mm, Sterile Packaged in 10 Magazines, Each with 100 Pads**

Description	Packaging	Order No.
Absorbent Pads, 10×100 pads	1,000 per box, incl. one dispenser	15410--47----ALR
Absorbent Pad Set, 10×100 pads plus 1,000 membrane filters (0.45 µm, white   green)	1,000 per box, incl. two dispensers	13906--47----APR

**Absorbent Pads, 47 mm, Sterile Packaged of 10 Discs per Sleeve**

Description	Packaging	Order No.
Absorbent Pad Set, 10×10 pads in sleeves plus 100 membrane filters (0.2 µm, white   black)	100 per box	13707--47----ALN
Absorbent Pad Set, 10×10 pads in sleeves plus 100 membrane filters (0.45 µm, white   black)	100 per box	13706--47----ALN

**Absorbent Pads, 50 mm, Sterile-Packaged in 10 Magazines, Each with 100 Pads**

Description	Packaging	Order No.
Absorbent Pads, 10×100 pads	1,000 per box, incl. one dispenser	15410--50----ALR

**Absorbent Pads, 50 mm, Sterile-Packaged in Petri Dishes**

Description	Packaging	Order No.
Absorbent Pad Set, 100 pads in petri dishes, sterile packaged	100 per box	15400--50-----N
Absorbent Pad Set, 100 pads in petri dishes plus 100 membrane filters (0.45 µm, green   dark green)	100 per box	15400--50----FRN

**Disposable Petri Dishes, Auto-Sterile, 100 per Box**

Diameter	Order No.
60 mm	14311--60-----N
90 mm	14311--90-----N

## ► Biosart® 100 Monitors



The membrane filtration method is the suitable technique for microbiological analysis of pharmaceuticals, water, cosmetics, foods and beverages. The use of ready-to-use disposable units is optimal for these applications.

### Biosart® 100 Monitors

Biosart® 100 Monitors have been specifically designed for the detection and enumeration of microorganisms in pharmaceuticals, cosmetics, food, beverages, water and other liquids. These sterile disposables with an incorporated membrane filter and cellulose pad are ready to use. After filtration, just remove the 100 ml funnel to convert the Monitor into a petri dish eliminating the need for membrane manipulation. Culture media for wetting the pad are available in individually sterilized, convenient plastic ampoules. Biosart® 100 Monitors are ready-to-use filter units designed to be placed onto the bases of a vacuum manifold, eliminating the cleaning and sterilization required of reusable funnels.

### Compliance with International Standards

The membrane filter method is worldwide accepted and the preferred method of choice for the analysis of microbial contamination in liquid samples. Biosart® 100 Monitors and Media are in compliance with the membrane filtration procedures referenced in the:

- European drinking water directive (Council Directive 98/83/EC on the quality of water)
- Standard Methods for the Examination of Water and Waste Water, 20th edition
- U.S. Environmental Protection Agency, 600/8-78-017.

- International Standard's microbiological methods, such as ISO 7704, ISO 9308-1, DIN EN ISO 16266, ISO 8199
- WHO Guidelines for Drinking Water Quality, 1997
- International Pharmacopoeia, such as the current editions of the USP and EP

### High Flow Membranes

Biosart® 100 Monitors are also available with the new 0.45 µm High Flow membranes. The special pore structure allows shorter filtration times due to 30% higher flow rates. Especially E. coli shows best growth promotion on High Flow Membranes.

### Applications

Colony counting, particle testing and microscopy

Some of the advantages you will benefit from when using Biosart® 100 Monitors:

### Superior Performance

- High flow rate
- High total throughput

### Safe & Reliable

- Sterile or individually, sterile packaged
- Consistently recovery
- Membranes meet ISO 7704
- Membranes available in various colors
- Without any hydrophobic adhesive areas

### Economical

- Ready to connect and easy to use
- Minimal amount of equipment needed

## ► Specifications

Housing	Polystyrene
Membrane filter	Cellulose nitrate (cellulose ester): choice of white, green or grey, with grid; Regenerated cellulose: white; membranes removable for filling
Plug and adapter	Polyethylene
Pad	Cellulose
Capacity	100 ml, 10 ml graduations
Pore size	0.2 µm, 0.45 µm or 0.8 µm
Filter diameter	47 mm
Filtration area	14.5 cm <sup>2</sup>
Max. operating pressure	Vacuum only
Outlet	6.5 × 1.5 mm
Lot certificates	Recovery rate, sterility and specifications

**Biosart® 100 Monitors, 100 ml, 47 mm, Individually Packaged, Sterile, 48 Units**

Pore Size	Membrane Filter* Color   Grid Color	Order No.
0.2 µm	CN white   black	16401-47-07--ACK
0.45 µm	CN white   black	16401-47-06--ACK
0.45 µm	CN green   dark green	16402-47-06--ACK
0.45 µm	CN gray   white**	16403-47-06--ACK

**Biosart® 100 Monitors, 100 ml, 47 mm, Packaged on Trays, Sterile, 48 Units**

0.2 µm	CN white   black	16401-47-07----K
0.45 µm High Flow	CN white   black	16401-47-H6----K
0.45 µm	CN white   black	16401-47-06----K
0.45 µm	CN green   dark green	16402-47-06----K
0.45 µm	CN gray   white**	16403-47-06----K
0.8 µm	CN gray   white**	16403-47-04----K
0.45 µm	RC white	16404-47-06----K

**Biosart® 100 Monitors, 100 ml, 47 mm, Sterile, 48 Units**

0.45 µm High Flow	CN white   black	16401-47-H6-V--K
0.45 µm	CN white   black	16401-47-06-V--K
0.45 µm	CN gray   white**	16403-47-06-V--K
0.8 µm	CN gray   white**	16403-47-04-V--K

**Biosart® 100 Monitors, 100 ml, 47 mm, Sterile, 48 Units, Membrane Fixed**  
available only in the U.S. and Canada

0.45 µm High Flow	CN white   black	16401-47-H6-VWMK
0.45 µm	CN white   black	16401-47-06-VWMK
0.45 µm High Flow	CN gray   white**	16403-47-H6-VWMK
0.45 µm	CN gray   white**	16403-47-06-VWMK

\* CN = Cellulose Nitrate (Cellulose ester)

RC = Regenerated Cellulose

\*\* Gray membranes after wetting black

**Biosart® 100 Monitor Adapters and Membrane Lifter**

Description	Adaptation	Order No.
Biosart® 100 Adapter, polypropylene and silicone O-ring	Biosart® 100 Monitor onto Sartorius Stedim Biotech stainless steel base 1ZU---0002 Microsart® Base 47 mm (stainless steel base for Combisart® and Microsart® Combi.jet)	16424
Biosart® 100 Adapter, silicone	Biosart® 100 Monitor onto Sartorius Stedim Biotech stainless steel frits e.g. 16840 (Combisart® single base, 50 mm) or onto 16841 (individual base)	16414
Biosart® 100 Adapter, polypropylene	Biosart® 100 Monitor onto 50 mm supports	16415
Biosart® 100 Adapter, polypropylene	Biosart® 100 Monitor onto 56 mm supports and vacuum pumps	16416
Biosart® 100 Membrane Lifter, ABS	For easy transfer of the membrane onto agar	16417

## ▶ Biosart® 100 Nutrient Media



Each box of Biosart® 100 Nutrient Media contains 50 ampoules with sterile media, each with 2.5 ml and a lot certificate. If stored under proper conditions (+4°C), the culture media have a shelf life of 12 month (except for Endo, KF Strep, Lauryl Sulfate and Tergitol which have a 9-month shelf life). Biosart® 100 Nutrient Media comply with international regulations and recommendations: International pharmacopoeias, DIN and ISO standards, the American Standards for Water and Foods, mineral water regulations, guidelines of the food and beverage industries.

Within the scope of the quality assurance procedure and the stringent quality control standards every batch has passed Sartorius Stedim Biotech in-house tests of growth promotion, sterility, physical and technical parameters have been passed successfully. Biosart® 100 Nutrient Media are convenient in use and eliminating the handling of glass ampoules.

### **Application**

Colony counting

Some of the advantages you will benefit from when using Biosart® 100 Media:

### **Safe & Reliable**

- Pre-sterilized media
- Certificate of Quality for every batch
- In compliance with international standards
- Consistently recovery

### **Economical**

- Ready-to-use
- Long shelf life

**Biosart® 100 Nutrient Media, 2.5 ml, Individually,  
Sterile-Packaged in Ampoules, 50 Units**

Determination of	Media Type	Order No.
Total count	Caso (acc. USP)	16400-02----CA-K
Total count	R2A (acc. EP)	16400-02----RA-K
Total count	TGE   Total Count	16400-02----TC-K
Total count	Total Count TTC	16400-02----TZ-K
E. coli and coliforms	m Endo	16400-02----EN-K
E. coli and coliforms	m FC	16400-02----MF-K
E. coli and coliforms	Lauryl Sulfate   Teepol	16400-02----LS-K
E. coli and coliforms	Tergitol TTC	16400-02----TT-K
Enterococci	KF Strep   Azide	16400-02----KF-K
Pseudomonas aeruginosa	Cetrimide	16400-02----CE-K
Yeasts and molds	Sabouraud (acc. USP)	16400-02----SB-K
Yeasts and molds	m Green yeast and mold   Schaufus Pottinger	16400-02----MG-K
Yeasts and molds	m Green yeast and mold selective	16400-02----GS-K
Yeasts and molds	Wort	16400-02----WZ-K
Yeasts and molds and bacteria	WL Nutrient   Wallerstein Nutrient	16400-02----WN-K
Bacteria in fermentation processes	WL Differential   Wallerstein Differential	16400-02----WL-K
Acid-tolerant microorganisms	Orange Serum	16400-02----OS-K

## ► Microsart® @filter 100 Microsart® @filter 250

### Sterile Disposable Filter Units for Advanced Colony Counting



The process of producing pharmaceuticals and bringing new drugs to the market is becoming an increasingly costly business. The pharmaceutical and biotech industries are driven by the need to optimize their work flows and increase efficiency without compromising their level of safety. Products and raw materials used in the pharmaceutical or biotech industry require control of microbial levels during processing and handling. Microorganisms in liquids are quantified by the membrane filtration method. Use of this membrane filtration method allows accurate quantification of bacteria, yeasts and molds when low counts in a high sample volume are anticipated. All components of the filtration system must comply with international guidelines, such as USP, EP or ISO standards.

#### Description

Microsart® @filter 100 and 250 filter units are a ready-to-use combination of funnel, filter base and gridded membrane in one unit. The range of Microsart® @filter types has been tailored to meet individual needs: It is possible to choose between two volume sizes, 100 ml and 250 ml, different pore sizes and different filter colors for contrasting backgrounds during evaluation. The filter units exist as tray versions with lids or are stacked in bags for safe removal using the Microsart® Funnel Dispenser.

Despite the diversity of Microsart® @filters one thing is common: The optimal design.

- Click-Fit fastening allows for easy removal of funnels
- Leaking-free procedure due to innovative Click-Fit and bayonet closures
- Bayonet closure allows for easy mounting and removal of units
- Sterile Filter Base with recesses allows for simple membrane removal
- Innovative geometry of the funnel allows for effective rinsing after filtration (no sample residue is left in the funnel)

They have been specifically developed for the detection and enumeration of microorganisms in pharmaceuticals, biopharmaceuticals and cosmetics.

#### Microsart® @vance®

The Microsart® product family consists of all the most recent products from SSB for microbiological analysis, which are especially characterized by innovation and clever design.

The Microsart® @filter unit kicks off the new product line Microsart® @vance®. @vance® stands for even more progress and intelligent design, enhanced safety and thus more reliable results. The products in the Microsart® @vance® line have been specially developed for analyses in the pharmaceutical and biotechnological industry. Following the trend of using single-use products, these products are delivered sterile, ready-to-use and can be disposed of in an environmentally friendly manner. Microsart® @filter not only saves time and labor costs but minimizes the risk of secondary contamination – that's advanced colony counting by Sartorius Stedim Biotech.

#### Microsart® Funnel Dispenser

The Funnel Dispenser for secure removal of single, sterile Microsart® @filter has proven itself in practice. Even after opening the bag, the remaining funnels are protected from secondary contamination. The Microsart® Funnel Dispenser is made of high-grade stainless steel, the dispenser opening is made of polypropylene and contains a silicone O-ring. All these materials guarantee reliable autoclaving.

#### Applications

Colony counting and microscopy

Some of the advantages you will benefit from when using Microsart® @filter units:

#### Safe and Reliable

- **Sterile Packaged**  
Sterilization at the point of use is not required
- **Fully Disposable Base and Funnel**  
Preparation- and sterilization-free procedure reduces the risk of secondary contamination
- **Optimized Design and Materials**  
No liquid remains after filtration, eliminates the need of rinsing

#### Easy Handling

- **Click-Fit Closure**  
Fast in routine analysis, eliminates the risk of leakage

#### Economy

- **Adaptable on Combisart®**  
Given flexibility, no additional investment required
- **Transparent Funnel Material**  
Visibility of the complete filtration



## ► Specifications

Materials	Funnel: Polypropylene, Base: Polypropylene, Membrane filter: Cellulose Nitrate (C. Ester), Regenerated Cellulose; choice of various colors and grids
Capacity	100 ml, graduations at 20, 50 and 100 ml 250 ml, 50, 100, 200 and 250 ml graduations
Filter diameter	47 mm, prefilter 40 mm (particle testing only)
Filtration area	13.2 cm <sup>2</sup>
Max. operating pressure	Vacuum only
Sterilization	Gamma irradiation
Lot certificate	Recovery rate, sterility and performance test

### Microsart® @filter 100, Sterile Disposable Filter Units with Lid, 47 mm, 100 ml, Packaged on Trays, Ideal for the Use in Clean Benches, 24 Units

Pore Size	Membrane Filter* Color   Grid Color	Order No.
0.2	CN white   black	16D01--10-07--TG
0.45, High Flow	CN white   black	16D01--10-H6--TG
0.45, High Flow	CN gray   white**	16D03--10-H6--TG
0.45	CN green   dark green	16D02--10-06--TG
0.45	RC white (w/o grid)	16D05--10-06--TG
0.45	CN white   black	16D01--10--06--TG

### Microsart® @filter 250, Sterile Disposable Filter Units with Lid, 47 mm, 250 ml, Packaged on Trays, Ideal for the Use in Clean Benches, 16 Units

Pore Size	Membrane Filter* Color   Grid Color	Order No.
0.2	CN white   black	16D01--25-07--TF
0.45, High Flow	CN white   black	16D01--25-H6--TF
0.45, High Flow	CN gray   white**	16D03--25-H6--TF
0.45	CN green   dark green	16D02--25-06--TF
0.65	CN gray   white**	16D03--25-05--TF
0.45	CN white   black	16D01--25--06--TF

### Microsart® @filter 100, Sterile Disposable Filter Units, 47 mm, 100 ml, Stacked and Packaged in Bags, Ideal for the Use with Microsart® Funnel Dispenser, 60 Units

Pore Size	Membrane Filter* Color   Grid Color	Order No.
0.2	CN white   black	16D01--10-07--BL
0.45, High Flow	CN white   black	16D01--10-H6--BL
0.45, High Flow	CN gray   white**	16D03--10-H6--BL
0.45	CN green   dark green	16D02--10-06--BL
0.45	RC white (w/o grid)	16D05--10-06--BL
0.45	CN white   black	16D01--10--06--BL

### Microsart® @filter 250, Sterile Disposable Filter Units, 47 mm, 250 ml, Stacked and Packaged in Bags, Ideal for the Use with Microsart® Funnel Dispenser, 48 Units

Pore Size	Membrane Filter* Color   Grid Color	Order No.
0.2	CN white   black	16D01--25-07--BK
0.45, High Flow	CN white   black	16D01--25-H6--BK
0.45, High Flow	CN gray   white**	16D03--25-H6--BK
0.45	CN green   dark green	16D02--25-06--BK
0.65	CN gray   white**	16D03--25-05--BK
0.45	CN white   black	16D01--25--06--BK

#### Accessories

Description	Order No.
Microsart® Funnel Dispenser	16A08

Funnel dispenser for secure removal of single, sterile Microsart® @filter packaged in bags

\* CN = Cellulose Nitrate (Cellulose ester), RC = Regenerated Cellulose

\*\* Gray membranes after wetting black

## ► Microsart® Funnel 100 Microsart® Funnel 250

Sterile Disposable Funnels with Click-Fit



In microbiological quality control, sterility of the equipment used for processing samples is a necessary basic requirement. The re-useable funnels made of stainless steel or other materials which are used for membrane filtration are usually sanitized between samples by flaming or with hot water. Both of these methods can be insufficiently reliable if not properly performed. Alternatively, the funnels can be sterilized by autoclaving, but this is too laborious for routine use. A disposable filter funnel is the ideal combination for reliability and time saving.

### Description

Microsart® Funnels are sterile plastic funnels, which are available for the filtration of various sample volumes. They allow quick performance of the filtration steps required in the routine testing of water, food and beverages, pharmaceutical and cosmetic products.

A Sartorius Stedim Biotech 47 mm gridded membrane is placed on a stainless steel filter support. A Microsart® Funnel is simply and practically fitted on. The sample is filtered.

The funnel is made of polypropylene and thus is elastic enough for optimal sealing with a Click-Fit closure. Graduations are marked to allow accurate sample volumes. The large inner diameter ensures a high flow rate. The optimized shape allows thorough rinsing of the system subsequent to filtration. No liquid is retained in the filter funnel.

### Microsart® Base 47 mm

The Microsart® Base 47 mm is the perfect addition to existing Combisart® and Microsart® Combi.jet stainless steel manifolds. The slightly recessed frit ensures the plane positioning of the membrane filter. Thus wrinkled membranes, which make the counting of the colony growth difficult, are eliminated. Lateral notches make sure that the membrane can be removed easily after filtration.

### Microsart® Funnel Dispenser

The Funnel Dispenser for secure removal of single, sterile Microsart® Funnels has proven itself in practice. Even after opening the bag, the remaining funnels are protected from secondary contamination. The Microsart® Funnel Dispenser is made of high-grade stainless steel, the dispenser opening is made of polypropylene and contains a silicone O-ring. All these materials guarantee reliable autoclaving.

### Applications

Colony counting, particle testing and microscopy

Some of the advantages you will benefit from when using Microsart® Funnel 100:

#### – Reliable Results

Use a new, sterile funnel for each test for certain prevention of cross contamination!

#### – Time-Saving

Just change the funnel, rather than spending time sanitizing it!

#### – Simpler Handling

No more holding hot funnels! And, you can see when filtration has been completed, particularly useful when using manifolds in routine testing.

### ▷ Specifications

Material	Polypropylene
Capacity	100 ml, graduations at 20, 50 and 100 ml 250 ml, graduations at 50, 100, 200 and 250 ml
Filter diameter	47 mm, prefilter 40 mm (particle testing only)
Filtration area	13.2 cm <sup>2</sup>
Max. operating pressure	Vacuum only
Sterilization	Ethylene oxide
Lot certificate	Sterility and performance test

#### **Microsart® Funnel 100, Sterile Disposable Funnel, 100 ml, 100 Units**

Description	Order No.
Microsart® Funnel 100, sterile in 5 sealed bags	16A07--10-----N

#### **Microsart® Funnel 250, Sterile Disposable Funnel, 250 ml, 96 Units**

Description	Order No.
Microsart® Funnel 250, sterile in 6 sealed bags	16A07--25-----N

#### **Accessories and Replacement Parts**

Description	Order No.
Microsart® Funnel Dispenser Funnel dispenser for secure removal of single, sterile Microsart® Funnels	16A08
Microsart® Base 47 mm, with frit, stainless steel base for Combisart® and Microsart® Combi.jet Optimized for the use with 47 mm membranes, Click-Fit closure for Microsart® Funnel, Microsart® @filter and other funnel types sealed by bayonet closure	1ZU---0002
Silicone O-ring for Microsart® Base 47 mm male thread (pack size 3)	6980274
Replacement frit for Microsart® Base, stainless steel	1ZU---0001

Further information about Microsart® Combi.jet and Combisart® stainless steel manifolds you will find on the following pages.

## ► Biosart® 250 Funnels



In microbiological quality control, sterility of the equipment used for processing samples is a necessary basic requirement. The reusable funnels made of stainless steel or other materials which are used for membrane filtration are usually sanitized between samples by flaming or with hot water. Both of these methods can be insufficiently reliable when not properly performed. Alternatively, the funnels could be sterilized by autoclaving, but this is too laborious for routine use. A disposable sterile funnel in a certified quality is the ideal solution.

### Description

The Biosart® 250 Funnel has been specifically designed for microbiological and analytical quality assurance. Biosart® 250 are sterile funnels which allows for fast filtration required in the routine testing of pharmaceutical and cosmetic products, water, food and beverages and other liquids. A Sartorius Stedim Biotech gridded membrane is placed on a stainless steel filter support. A Biosart® 250 Funnel is simply fitted on and the sample is filtered. The funnel is made of polypropylene and is sufficiently elastic for optimal sealing with a bayonet-type closure. Graduations are marked at 50, 100, 150, 200 and 250 ml for exact sample volumes. The large inner diameter ensures a high flow rate. The conical form allows a thorough rinsing of the system subsequent to filtration. No liquid is retained in the filter funnel.

### Applications

Colony counting, particle testing and microscopy

Some of the advantages you will benefit from when using Biosart® 250 Funnels:

### Superior Performance

- High flow rate
- High total throughput

### Safe & Reliable

- Sterile or individually, sterile packaged
- No risk of cross contaminations
- No leakages due to proven closure technique
- No holding of hot funnels
- Visibility of the complete filtration

### Economical

- Ready to connect and easy to use
- Minimal amount of equipment needed
- Autoclavable (to a limited extend)

### ▷ Specifications

Material	Polypropylene
Capacity	250 ml, 50 ml graduations
Filter diameter	47 mm (or 50 mm), prefilter 40 mm
Filtration area	12.5 cm <sup>2</sup>
Max. operating pressure	Vacuum only
Sterilization	Ethylene oxide
Lot certificates	Sterility and performance tests

#### **Biosart® 250 Funnels, Ready to Use Filter Funnels, 250 ml, 50 Units**

<b>Description</b>	<b>Order No.</b>
Biosart® 250 Funnel, 50 units, individually, sterile-packaged	16407--25----ACK
Biosart® 250 Funnel, 50 units, sterile-packaged	16407--25----ALK

Further information available on request f.o.c. Order no. SL-3017-e

## ► Combisart® – The Sterile-Vented Filter Station

### Individual and Multi-Branch Systems



The Sartorius Stedim Biotech Combisart®, system enables you to select the optimal hardware and consumables for your needs in microbiological analysis or particle count in quality assurance. Combisart® features a modular design and field-proven standard accessories to make your choice easier.

#### Description

At the heart of the Combisart® system is a high-grade stainless steel manifold or individual system designed to accommodate all types of filter holders and funnels such as:

- Ready-to-use units like Microsart® Funnels 100 and 250, Microsart® @filter 100 and 250, Biosart® 100 Monitors and Biosart® 250 Funnels
- Flammable units such as stainless steel funnels for colony counting
- Autoclavable reusable funnels made of glass or polycarbonate



The outlet of the 1- and 3-branch manifolds are newly Quick Connection Nipples, which could be used together with Quick Connection Couplings (more information under Microsart® Combi.jet) or as hose nipples for vacuum tubings. The low height of the manifold ports is particularly advantageous for working on a clean bench. For low number of samples, we recommend the use of the 1-branch manifold 16844 or the individual base 16841 on the top of a suction flask. For large number of samples, we recommend the 3- or 6-branch manifolds.

#### Sterile Venting

A special feature of the Combisart® system is the stainless steel three-way valve (tap). They allow the vacuum for each filter holder to be individually controlled and each filter station to be sterilely vented. This rules out secondary contamination of the underside of the filter.

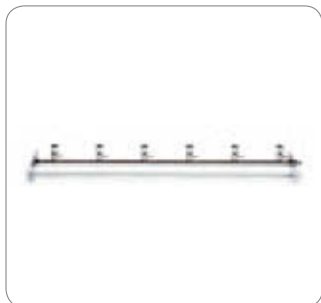

#### Sterilization

The system is compliant with ISO 8199 with regards to the sterilization methods of the equipment described in the "General Guide to enumeration of micro-organisms by culture". Since the most reliable sterilization method is autoclaving, the Combisart® design offers a unique advantage for this method. After inserting the membrane filters in the filter holders, you can simply unscrew them as an entire unit from each workstation and autoclave them. This method increases reliability and saves sterilization capacity.

#### The Right Equipment for Your Application

In connection with the single base 16840 (for 50 mm membranes) the manifolds are flexible to adapt disposable Biosart® 250 or stainless steel funnels. The stainless steel filter support of the single base 16840 allows a homogeneous distribution of the residues on the membrane filter surface.

Alternatively to 16840 the Microsart® Base 47 mm 1ZU---0002 is highly recommended for all 47 mm membrane filters, Microsart® Funnels and for Microsart® @filter.

The Biosart® 100 adapter 16424 ensures that the Monitors are positioned perfectly, minimizing the risk of contamination during filtration.

3 or 6 polycarbonate holders of the type 16511 can be screwed onto the manifold directly.

Glass units (16306 or 16307) can be fitted by using corresponding adapter- | stopper-combinations.

**Maximum Flexibility**

The turnable single base for 50 mm membranes 16840 or the Microsart® Base 47 mm features additional advantages you will benefit from:

- You can pour out a non-filterable sample from each unit
- Filtration equally easy for left- or right handed users in your laboratory, because funnels can be positioned to suit the individual user

Some of the advantages you will benefit from when using the Combisart® System:

**Safe & Reliable**

- Sterile venting of each membrane after filtration
- Sterilization acc. to ISO 8199
- Special polished stainless steel surfaces allow easy cleaning & rinsing
- Low height is advantageous for working on a clean bench

**Saves Time**

- Filtration of 3 or 6 samples in parallel
- Easy pouring out of non-filterable samples
- Equally easy for right- and left-handed users

**Economical**

- Maximum flexibility due to different set-ups
- Space-saving in the autoclave
- Stainless steel 304 – long lifecycle

**Combisart® Hardware-Setups**

Filtration systems fast and easy completed at [www.sartorius-stedim.com/microbio](http://www.sartorius-stedim.com/microbio)

**Specifications**

Stainless steel quality	High-grade stainless steel: B.S. 304S31   AISI 304
Dimensions in mm (L   H   D)	3-branch manifold: 435   103   120 6-branch manifold: 910   103   120
Max. operating pressure	Vacuum only
Sterilization	By autoclaving (max. 134°C), By dry heat (max. 180°C), By flaming, By other methods acc. to ISO 8199
Parts and materials	Lid, funnel, base part, filter support, clamp and tap made of stainless steel. Silicone flat gasket. Silicone lid seal
Flow rate per filter station for water at 90% vacuum	200 ml/min with 0.2 µm membrane filter 600 ml/min with 0.45 µm membrane filter
Filtration area	12.5 cm <sup>2</sup> (if using stainless steel funnels)
Suitable membrane filter diameter	50 mm (47 mm, if using a 47 mm frit 6980103)
Outlet spout (individual system)	10 mm outer diameter
Inlet (branches only)	Female thread, TR 20×2
Outlet (1- and 3-branches only)	Quick Connection Nipple DN 7 (tubings with DN 10 are connectable)
Outlet (6-branch)	Hose nipple DN 10

**Combisart® Individual System and Multi-Branch Manifolds, Made of High-Grade Stainless Steel, Pre-Assembled with Stainless Steel Funnels and Lids**

Description	Capacity	Order No.
Combisart® individual filter holder, stainless steel, 100 ml	1 × 100 ml	16219-CS
Combisart® individual filter holder, stainless steel, 500 ml	1 × 500 ml	16201-CS
Combisart® 1-branch stainless steel manifold, 100 ml	1 × 100 ml	16844-CS
Combisart® 1-branch stainless steel manifold, 500 ml	1 × 500 ml	16845-CS
Combisart® 3-branch stainless steel manifold, 100 ml	3 × 100 ml	16824-CS
Combisart® 3-branch stainless steel manifold, 500 ml	3 × 500 ml	16828-CS
Combisart® 6-branch stainless steel manifold, 100 ml	6 × 100 ml	16832-CS
Combisart® 6-branch stainless steel manifold, 500 ml	6 × 500 ml	16831-CS

**Combisart® Individual and Multi-Branch Bases, Made of High-Grade Stainless Steel, Without Funnels and Lids, to Accommodate Various Funnel Types**

Description	Order No.
Combisart® individual base, stainless steel, with frit (50 mm), to accommodate stainless steel funnels and Biosart® 100   250	16841
Combisart® 1-branch stainless steel manifold, without frit	16844
Combisart® 3-branch stainless steel manifold, without frits	16842
Combisart® 6-branch stainless steel manifold, without frits	16843
Combisart® Single base with frit (for 50 mm membranes), stainless steel, accommodate stainless steel funnels and Biosart® 100   250	16840
Microsart® Base 47 mm, with frit, stainless steel base for Combisart® and Microsart® CombiJet Optimized for the use with 47 mm membranes, Click-Fit closure for Microsart® Funnel, Microsart® @filter and other funnel types sealed by bayonet closure	1ZU---0002

Combisart® Hardware Set-Ups – Choose complete filtration systems easy and fast under: <http://www.sartorius-stedim.com/microbio>

Replacement Parts for Combisart® Individual Filter Holders

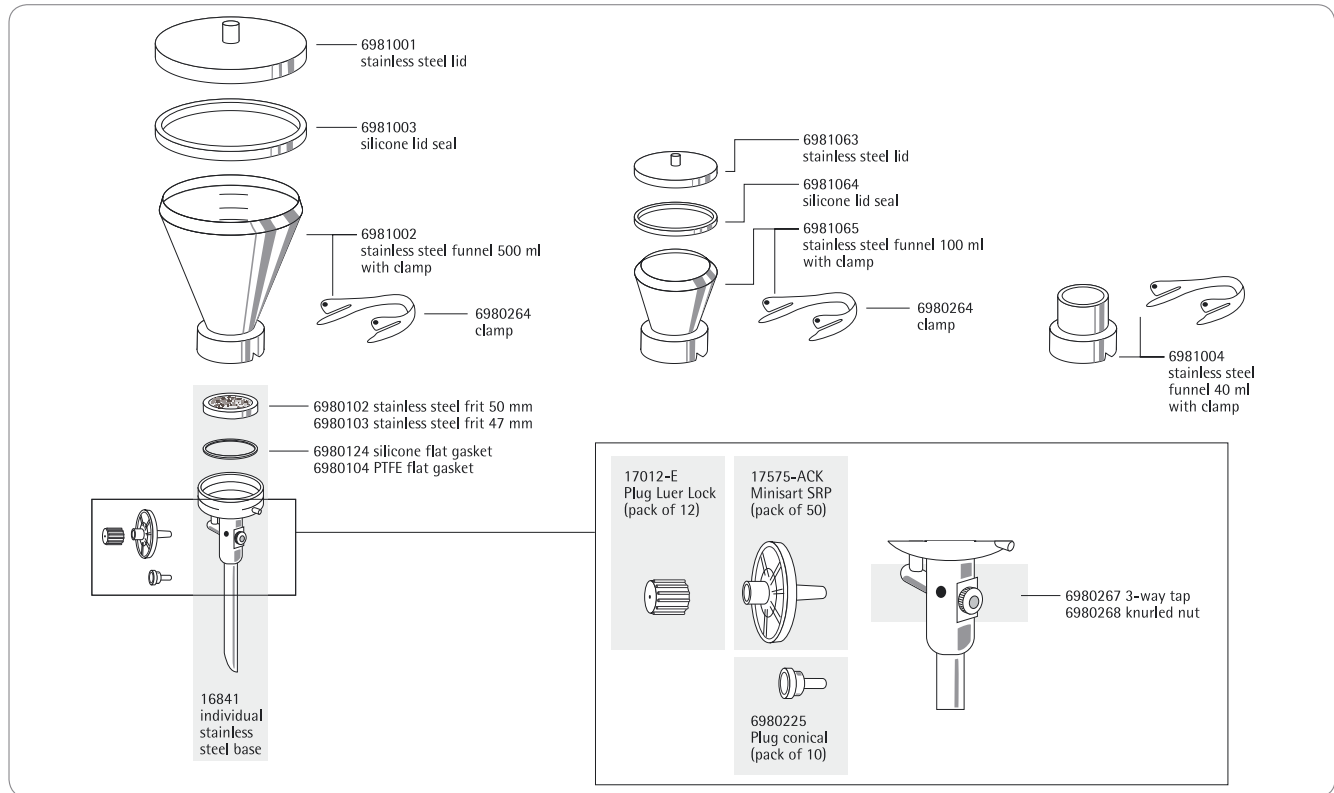

Replacement Parts for Combisart® Manifolds

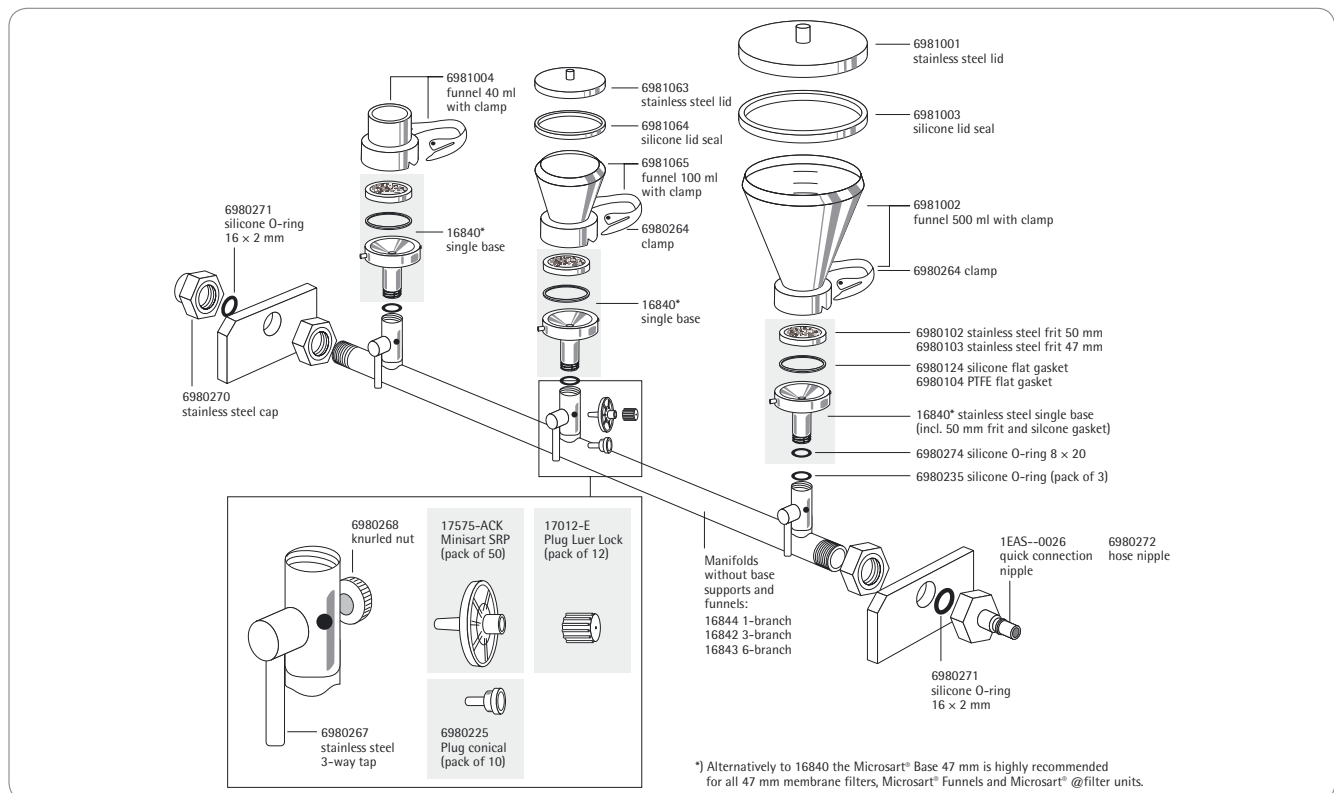

\*) Alternatively to 16840 the Microsart® Base 47 mm is highly recommended for all 47 mm membrane filters, Microsart® Funnels and Microsart® filter units.



**Accessories and Replacement Parts for the Combisart® System**

Description	Quantity	Order No.
Minisart® SRP25, sterile filter for venting, 0.2 µm, individually sterile-packaged, could be autoclaved 5 times.	50	17575-----ACK
Plug luer lock, to close the Minisart® inlet, if sterile venting is not required	12	17012-----E
Plug, conical, to close the venting hole beside the 3-way-valve, if sterile venting is not required	10	6980225
Silicone O-ring for single base 16840 male thread (also 1ZU---0002)	3	6980274
Silicone O-ring for manifold female threads	3	6980235
Silicone flat gasket underneath the frit (16840)	1	6980124
PTFE flat gasket underneath the frit (16840)	1	6980104
Stainless steel frit, 50 mm diameter (16840)	1	6980102
Stainless steel frit, 47 mm diameter (16840)	1	6980103
Quick Connection Nipple, stainless steel	1	1EAS--0026
Hose nipple, stainless steel, DN 10	1	6980272
Stainless steel frit for Microsart® Base 47 mm (1ZU---0002)	1	1ZU---0001

**Funnels, Lids, Seals and Filter Holders to Connect on the Combisart® System**

Description	Capacity	Membrane Filter Diameter	Order No.
Stainless steel funnel with closure clamp	100 ml	47   50 mm	6981065
Lid, stainless steel	for 100 ml funnel		6981063
Lid seal, silicone	for 100 ml funnel		6981064
Stainless steel funnel with closure clamp	500 ml	47   50 mm	6981002
Lid, stainless steel	for 500 ml funnel		6981001
Lid seal, silicone	for 500 ml funnel		6981003
Stainless steel funnel with closure clamp	40 ml	47   50 mm	6981004
Polycarbonate filter holder, complete with filter support and funnel	250 ml	47 mm	16511
Glass filter holder, complete with filter support, funnel and metal clamp	30 ml	25 mm	16306
Glass filter holder, complete with filter support, funnel and metal clamp	250 ml	47   50 mm	16307

**Combisart® Adapter, to Accommodate Various Funnel Types**

Description	Adaptation	Order No.
Biosart® 100 Adapter, silicone	Biosart® 100 Monitors onto 16840 (Combisart® single base) or onto 16841 (individual base)	16424
Biosart® 100 Adapter, stainless steel with silicone stopper	Biosart® 100 Monitors onto Combisart® manifolds 16844, 16842 and 16843	16835
Glass funnel Adapter, stainless steel with silicone stopper	16306   15 (glass funnel, 30 ml) onto Combisart® manifolds 16844, 16842 and 16843	16836
Glass funnel Adapter, stainless steel with silicone stopper	16307 (glass funnel, 250 ml) onto Combisart® manifolds 16844, 16842 and 16843	16837

## ► Microsart® Combi.jet

### 2-Branch Stainless Steel Manifold for Microbiological Analysis



The Microsart® Combi.jet is a 2-branch manifold, made of high-grade stainless steel. The manifold has been specifically designed for the use together with the Microsart® e.jet Transfer Pump. The system is able to create sufficient vacuum for vacuum filtration concomitantly transferring the filtered liquid directly to waste. Microsart® Combi.jet and Microsart® e.jet can be easily connected and disassembled by the innovative Quick Connection technology.

#### Compact Design

The complete traditional equipment, such as connectors, tubes, suction flask, protection filter, Woulff's bottle and a vacuum pump, requires a lot of laboratory space and is time consuming to operate and maintain. Microsart® Combi.jet reduces operating complexity due to its small and compact design. The Transfer Pump Microsart® e.jet fits visually and ergonomically into this design.

#### Quick Connection

Building-up the vacuum filtration system is easy and fast thanks to the innovative Quick Connection Coupling and Nipples at the Microsart® Combi.jet manifold and Microsart® e.jet Transfer Pump. Simply push-to-connect for assembling and pull-to-disassembling the whole system within seconds.

#### Sterile Venting

A special feature of the Microsart® Combi.jet manifold are the stainless steel three-way valves (taps). They allow the vacuum for each filter holder to be individually controlled and each filter station to be sterilely vented. This rules out secondary contamination of the underside of the filter.

#### Maximum Flexibility

The Microsart® Combi.jet enables you to select the optimal hardware and consumables for your needs in microbiological analysis in quality assurance. The heart of the whole system is the Microsart® Combi.jet, the stainless steel 2-branch manifold, designed to accommodate all types of filter holders and funnels such as:

- Ready-to-use units Microsart® @filter 100 and 250
- Ready-to-use units Microsart® Funnel 100 and 250
- Ready-to-use units Biosart® 100 Monitors
- Ready-to-use units Biosart® 250 Funnels
- Flammable units such as stainless steel funnels
- Autoclavable glass filter holders
- Autoclavable polycarbonate filter holder

#### Reliability: Ideal for Microbiology Applications

- Sterile venting after filtration
- Easy to clean and sanitize
- Smooth and reliable filtration

#### Economically Efficient

- Saving time due to Quick Connection technology
- Saving work space (saves 70%)
- No need of suction flasks and water traps

## ▷ Specifications

Stainless steel quality	High-grade stainless steel: B.S. 304S31   AISI 304
Dimensions in mm (L   H   D)	246   98   130
Max. operating pressure	Vacuum only
Sterilization	By autoclaving (max. 134°C)
Parts and materials	Manifold: stainless steel, silicone O-ring
Quick Connection Coupling	PVDF, closure: stainless steel, sealing: FKM   FPM
Inlet (manifold)	Female thread, TR 20 × 2
Outlet	Quick Connection Coupling (female), inner diameter NW 7, non-shut-off

### Microsart® Base 47 mm

Materials	stainless steel, silicone O-ring
Suitable membrane filter diameter	47 mm
Filtration area (e. g. for the use with Microsart® Funnels)	12.5 cm <sup>2</sup>

### Microsart® Combi.jet 2-Branch Manifold, Made of High-Grade Stainless Steel, Without Frits and Funnels, to Accommodate Various Funnel Types

Description	Order No.
Microsart® Combi.jet 2-branch manifold, without frits	16848-CJ
Microsart® Base 47 mm, with frit, stainless steel base for Combisart® and Microsart® Combi.jet Optimized for the use with 47 mm membranes, Click-Fit closure for Microsart® Funnel, Microsart® @filter and other funnel types sealed by bayonet closure	1ZU---0002

### Accessories and Replacement Parts for Microsart® Combi.jet

Description	Quantity	Order No.
Minisart® SRP25, sterile filter for venting, 0.2 µm, individually sterile-packaged, could be autoclaved 5 times	50	17575-----ACK
Plug luer lock, to close the Minisart inlet, if sterile venting is not required	12	17012-----E
Plug, conical, to close the venting hole beside the 3-way-valve, if sterile venting is not required	10	6980225
Silicone O-ring for Microsart® Base 47 mm male thread	3	6980274
Silicone O-ring for manifold female threads	3	6980235
Combisart® single base, stainless steel, optimal for the use with 50 mm membrane filters, funnel closure by bayonet or adapter	1	16840
Microsart® Combi.jet Coupling, Quick Connection, PVDF	1	1EAS--0022

Funnels and filter holders to connect onto the Microsart® Combi.jet manifold are equivalent to those for the use with the Combisart® system (page 38).

## ► How to Set-up a Vacuum Filtration System

### Microsart® Combi.jet 2-Branch Stainless Steel Manifold plus Microsart® e.jet

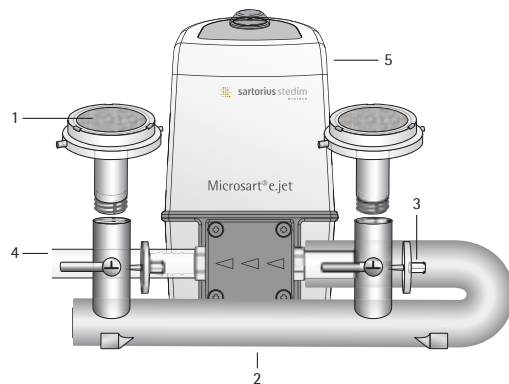

The filter stations are directly connected to the Transfer Pump for simultaneous transfer of the filtrate to waste. Easy assembling thanks to Quick Connection technology.

### Order Information

Pos.	Description	Order Qty.	Order No.	Detailed Information on Page
Microsart® Combi.jet stainless steel equipment:				43
1	Microsart® Base 47 mm	2	1ZU---0002	
2	Microsart® Combi.jet 2-branch manifold	1	16848-CJ	
Sterile venting of the filter station:				41
3	Minisart® SRP25, 0.2 µm	1	17575-----ACK	
4	Silicone tubing, pressure-sided, 1 m	2*	1ZAS--0007	55
Vacuum Pump:				54
5	Microsart® e.jet Transfer Pump, 230 V, 50 Hz	1	166MP-4	
Additional accessories:				
	Microsart® @filter 100, sterile filter units, packaged on trays	1	16D01--10-H6--TG	32
	Stainless steel tweezers	1	16625	59
	Colony Counter	1	17649	58
	Incubator	1	18119	58
	Container for anaerobic incubation	1	16671	59

\* required length depends on distance between Transfer Pump and drain

## Combisart® 1-Branch Stainless Steel Manifold Plus Microsart® mini.vac

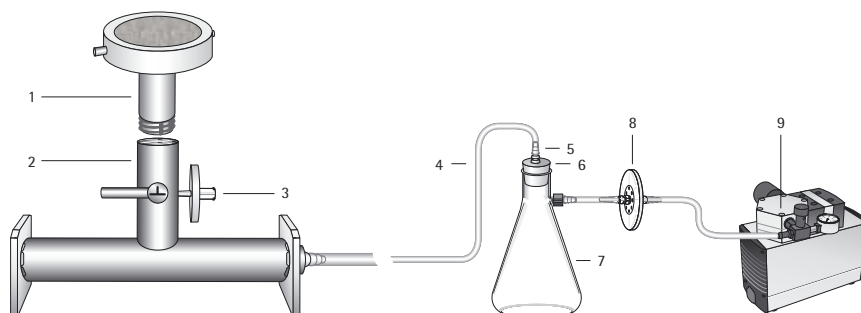

The filter station is connected to a suction flask, which is connected to a filtrate-protected vacuum pump.

### Order Information

Pos.	Description	Order Qty.	Order No.	Detailed Information on Page
Combisart® stainless steel equipment:				38
1	Combisart® single base, 50 mm	1	16840	
2	Combisart® 1-branch manifold	1	16844	
Sterile venting of the filter station:				41
3	Minisart® SRP25, 0.2 µm	1	17575-----ACK	
4	Rubber vacuum hose, 1 m	3*	16623	51
Suction flask and stopper:				50
5	Tube connector	1	17204	
6	Silicone stopper	1	17173	
7	Suction flask, 2 liters	1	16672	
Water trap for pump protection:				51
8	Vacusart®, 0.45 µm	1	17804-----M	
Vacuum Pump:				52
9	Microsart® mini.vac, 230 V, 50 Hz	1	16694-2-50-06	
Additional accessories:				
	Microsart® e.motion Dispenser	1	16712	12
	Stainless steel tweezers	1	16625	59
	Colony Counter	1	17649	58
	Incubator	1	18119	58
	Stainless steel prefilter attachment	1	16807	59
	Container for anaerobic incubation	1	16671	59

\* required length depends on distance between the filter station and the vacuum source

### Combisart® 1-Branch Stainless Steel Manifold plus Microsart® e.jet

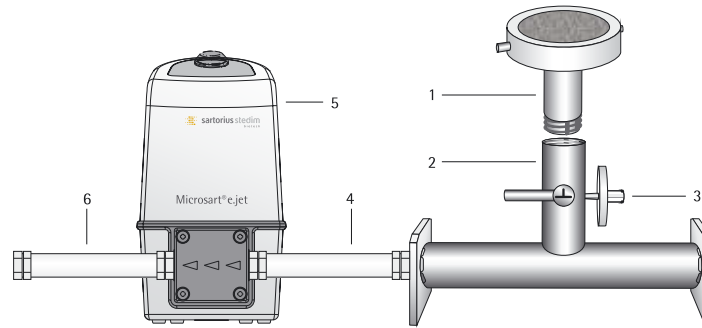

The filter station is directly connected to a vacuum fluid pump for simultaneous transfer of the filtrate to waste. Easy assembling thanks to Quick Connection technology.

#### Order Information

Pos.	Description	Order Qty.	Order No.	Detailed Information on Page
Combisart® stainless steel equipment:				38
1	Combisart® single base, 50 mm	1	16840	
2	Combisart® 1-branch manifold	1	16844	
Sterile venting of the filter station:				41
3	Minisart® SRP25, 0.2 µm	1	17575-----ACK	
4	Silicone tubing with Quick Connection Coupling, 20 cm, vacuum-sided	1	1ZA---0006	55
Vacuum Pump:				54
5	Microsart® e.jet Transfer Pump	1	166MP-4	
6	Silicone tubing, pressure-sided 1 m	2*	1ZAS--0007	55
Additional accessories:				
	Microsart® e.motion Dispenser	1	16712	12
	Stainless steel tweezers	1	16625	59
	Colony Counter	1	17649	58
	Incubator	1	18119	58
	Stainless steel prefilter attachment	1	16807	59
	Container for anaerobic incubation	1	16671	59

\* required length depends on distance between vacuum source and drain

## ► Traditional Multi-Branch Manifolds and Individual Filter Holders

Made of Stainless Steel, Glass and Polycarbonate



### Individual Filter Holders

The three stainless steel holder types differ only in the funnel capacity (either 40 ml, 100 ml or 500 ml). They have been designed specifically for applications in which the particles or microorganisms retained on the membrane filter surface are of interest. The stainless steel frit filter support ensures a uniform distribution of the residues.

Simple handling is very important regarding routine examinations. Stainless steel taps in the base allow the vacuum to be turned on and off. The special closure clamps simplify the addition or removal of the funnels adding to the ease of use.

### Multi-Branch Manifolds

The manifold systems are available with 100 ml or 500 ml capacity funnels. The three or six separate filter holders save time when mass examinations have to be carried out. Due to the stainless steel taps on the manifold ports, the vacuum for each holder can be turned on and off individually. The stainless steel frit allows homogenous distribution of the residues on the membrane filter surface. Funnel and filter support can be disinfected by flaming.

### Glass Filter Holders

These filter holders are available for the filtration of small volumes with a 30 ml top part and for larger volumes with a 250 ml top part. They can be sterilized by autoclaving (max. 134°C) or by dry heat (max. 180°C). The glass frit ensures uniform distribution of retained residue.

### Polycarbonate Filter Holders

Type 16510 is complete with receiver flask, and can be operated with vacuum as well as with slight overpressure (0.5 bar is recommended for highest standing times). Type 16511 is like 16510, but without receiver flask. It is used on a suction flask or a vacuum manifold e. g. Combisart® systems. Both devices can be sterilized by autoclaving (max. 121°C).

## ► Specifications

### Stainless Steel Multi-Branch Manifolds and Individual Filter Holders

Stainless steel quality	High-grade stainless steel: B.S. 304S31   AISI 304
Dimensions in mm (W   H   D)	3-branch manifold: 3 × 100 ml: 432   184   120 3 × 500 ml: 442   262   132 6-branch manifold: 6 × 100 ml: 906   268   120 6 × 500 ml: 916   329   132
Max. operating pressure	Vacuum or max. 2 bar pressure (29 psi)
Sterilization	By autoclaving (max. 134°C), By dry heat (max. 180°C), By flaming, By other methods acc. to ISO 8199
Parts and materials	Lid, funnel, base part, – filter support, clamp and tap made of stainless steel. Silicone flat gasket. Silicone lid seal
Flow rate per filter station for water at 90% vacuum	200 ml/min with 0.2 µm membrane filter 600 ml/min with 0.45 µm membrane filter
Filtration area	12.5 cm <sup>2</sup>
Suitable membrane filter diameter	50 mm (47 mm, if using a 47 mm frit filter support 6980103)
Outlet spouts (individual system)	10 mm outside diameter
Outlet (branches only)	Hose nipple, DN 10

Replacement Parts for Traditional Individual Filter Holders

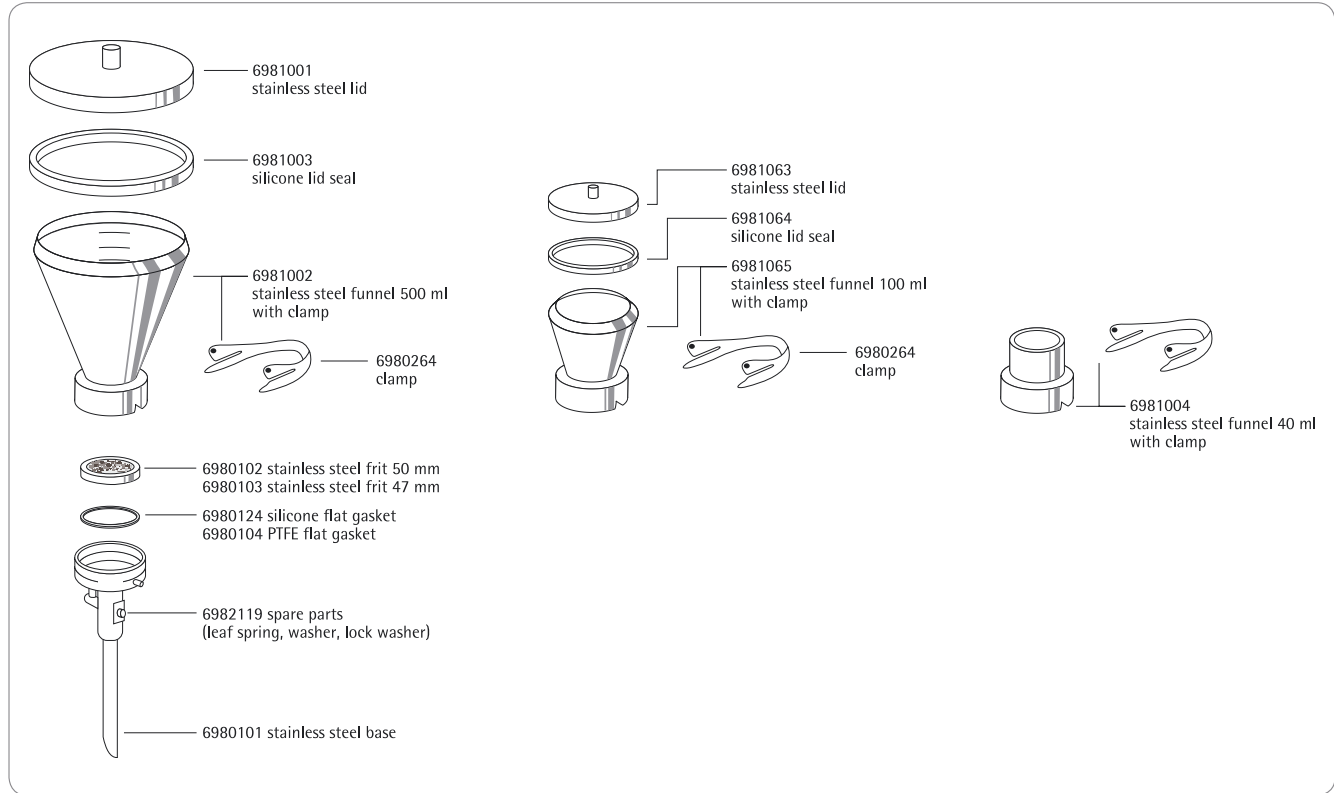

Replacement Parts for Traditional Manifolds

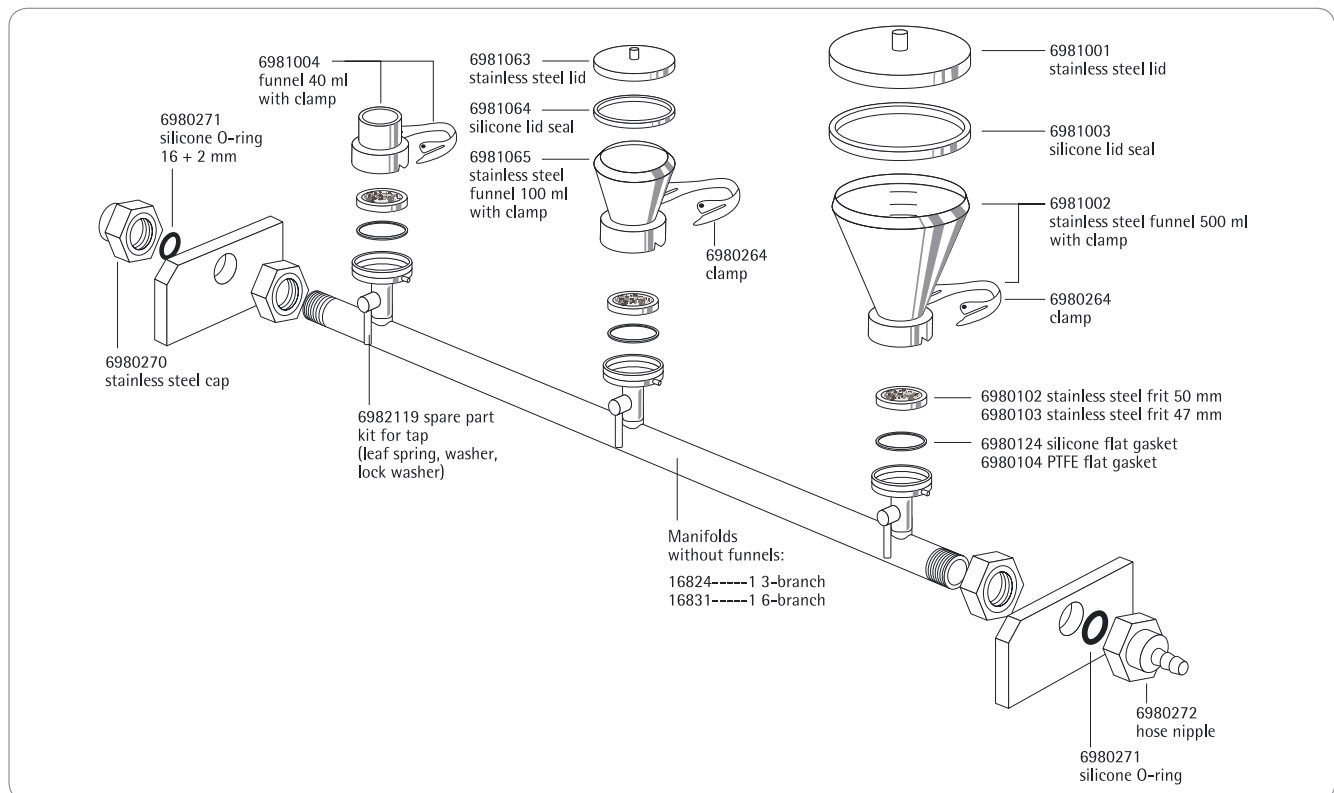



**Individual Stainless Steel Filter Holders, Pre-Assembled with Stainless Steel Funnels and Lids**

Description	Capacity	Order No.
Individual stainless steel filter holder, 100 ml	1 × 100 ml	16219
Individual stainless steel filter holder, 500 ml	1 × 500 ml	16201
Individual stainless steel filter holder without lid, 40 ml	1 × 40 ml	16220

**Multi-Branch Manifolds, Stainless Steel, with Stainless Steel Funnels and Lids**

Description	Capacity	Order No.
3-branch stainless steel manifold, 100 ml	3 × 100 ml	16824
3-branch stainless steel manifold, 500 ml	3 × 500 ml	16828
6-branch stainless steel manifold, 100 ml	6 × 100 ml	16832
6-branch stainless steel manifold, 500 ml	6 × 500 ml	16831

**Glass Filter Holders**

Description	Capacity	Membrane Filter Diameter	Order No.
Glass filter holder, complete with filter support, funnel and metal clamp	30 ml	25 mm	16306
Glass filter holder, complete with filter support, funnel and metal clamp	250 ml	47   50 mm	16307

**Polycarbonate Filter Holder**

Description	Capacity	Membrane Filter Diameter	Order No.
Polycarbonate filter holder, with 250 ml top part and receiver flask, for vacuum or pressure filtration	250 ml	47 mm	16510
Polycarbonate filter holder, with 250 ml top part, for vacuum filtration only	250 ml	47 mm	16511

## ► Accessories for Vacuum Filter Holders and Manifold Systems



### Suction Flasks and Stoppers

#### Suction Flask, 2 Liter Capacity

Vacuum-resistant flask made of duran 50 glass with plastic safety hose nipple according to the – German Industrial Standard No. 12476. Outer diameter of the hose nipple, 9 mm. Inner diameter of the opening, 60 mm. Stoppers are not enclosed.

A 1-liter capacity flask is available for countries which do not have safety restrictions on glass hose nipples.

#### Order Numbers for Suction Flasks

Description	Order No.
Suction flask, 5 liters acc. to DIN 12476, incl. stopper 75 D and glass tube	16672-----1
Suction flask, 2 liters acc. to DIN 12476, without stopper	16672
Tube connector for connecting a Combisart® stainless steel manifold to a suction flask 1 or 2 liters (not necessary when a Vacusart® is connected directly to the bored stopper)	17204
Suction flask, 1 liter (not available in countries which have safety restrictions on glass hose nipples)	16606

#### Replacement Parts for Suction Flasks

Description	Order No.
Glass tube for silicon stopper 75 D for suction flask 5 liters 16672-----1	1EAQ--0017
Bored stopper 75 D for suction flask 5 liters 16672-----1	1EAS--0019
Assembling kit for hose barb for suction flask 5 liters 16672-----1	1EA---0018
Hose barb, complete, Polypropylene, for suction flask 2 liters 16672	6983003

#### Order Numbers for Bored Stoppers for Suction Flask 2 Liters 16672

Description	Adaptation	Order No.
Silicone stopper	Combisart® individual base 16841 or other individual stainless steel filter holders (16201, 16219, 16220) onto the suction flask 16672	17173
Silicone stopper	16306   15 (glass funnels, 30 ml) onto the suction flask 16672	17174
Silicone stopper	16307 (glass funnel, 250 ml) onto the suction flask 16672	17175

#### Order Numbers for Bored Stoppers for Suction Flask 1 Liter 16606

Description	Adaptation	Order No.
Silicone stopper	Combisart® individual base 16841 or other individual stainless steel filter holders (16201, 16219, 16220) onto the suction flask 16606	17004
Silicone stopper	16306   15 (glass funnels, 30 ml) onto the suction flask 16606	17005
Silicone stopper	16307   16 (glass funnel, 250 ml) onto the suction flask 16606	17006

**Water Traps**

Used between suction flask and vacuum source, in order to prevent overflow of filtrate into an electric vacuum pump

**Vacusart®**

Vacusart® is a ready-to-connect filtration unit, consisting of a polypropylene housing and a hydrophobic, but air-permeable PTFE membrane with a pore size of 0.45 µm. Vacusart® is perfectly suitable for the protection of vacuum pumps. It could be put directly into the hole of the bored stopper and connected with the rubber hose to the vacuum pump.

**Description**

Vacusart® water trap, pack of 3

**Order No.**

17804-----M

**Woulff's Bottle, 500 ml**

Used between suction flask and vacuum source. Allows simple control of the vacuum with glass units without a separate tap and prevents furthermore the filtrate from overflowing from the suction flask.

**Description**

Woulff's bottle, 500 ml

**Order No.**

16610

**Rubber Vacuum Hose (1 Meter)**

Thick-walled rubber hose for connecting the system components, e. g. suction flasks, vacuum pumps, etc. When ordering, please state length required in meters.

**Description**

Rubber vacuum hose (1 meter)

**Order No.**

16623

## ► Electric Vacuum Pumps

**Microsart® mini.vac****Microsart® maxi.vac**

Neoprene membrane pumps with low noise level, oil- and maintenance-free; reliable sources of vacuum.

The new vacuum pump series provides up to date technology for daily use in the Microbiology laboratory environment.

The vacuum produced by the new pumps is controlled and can be easily adjusted to your specifications. Thus damageable cells (e.g. bacteria) are concentrated on the surface or a membrane filter under better conditions, which results in decreased sub lethals, higher recovery rates and shorter incubation times.



## ▷ Specifications

### Specifications of Electric Vacuum Pumps

	<b>Microsart® maxi.vac</b> <b>16694-2-50-22</b> <b>16694-1-60-22</b>	<b>Microsart® mini.vac</b> <b>16694-2-50-06</b> <b>16694-1-60-06</b>
Delivery	22 l/min	6 l/min
Ultimate Vacuum	100 mbar	100 mbar
Noise level [100 mbar]	57.5–59.0 dBA	53.5 dBA
Operating Pressure	1 bar	2.5 bar
Materials (contact with filtrate possible)	Aluminum, CR (Neoprene), NBR (Perbunan)	PPS, EPDM, FPM (Viton)
Connectors for Tube (mm)	ID 9	ID 4
Ambient Temperature	5... 40°C	5... 40°C
Mains	16694-2-50-22: 230 V   50 Hz 16694-1-60-22: 115 V   60 Hz	16694-2-50-06: 230 V   50 Hz 16694-1-60-06: 115 V   60 Hz
Motor Protection	IP 44	IP 20
Power P1	130 W	65 W
Operating Current	0.9 A	0.63 A
Weight	7.1 kg	1.9 kg
Dimensions W   H   D (mm)	261   204   110	164   141   90
Recommended application	All multi-branch manifolds	Single filtration run up to 3-branch manifolds

### Order Numbers

<b>Description</b>	<b>Order No.</b>
Microsart® maxi.vac for multiple filtration runs, 230 V, 50 Hz	16694-2-50-22
Microsart® maxi.vac for multiple filtration runs, 115 V, 60 Hz	16694-1-60-22
Microsart® mini.vac up to 3 filter stations in parallel, 230 V, 50 Hz	16694-2-50-06
Microsart® mini.vac up to 3 filter stations in parallel, 115 V, 60 Hz	16694-1-60-06

<b>Replacement Parts</b>	<b>Order No.</b>
Replacement kit for 16694-2-50-22 and -1-60-22, set of one membrane, two valve springs and two head seals	1ED---0055
Replacement kit for 16694-2-50-06 and -1-60-06, set of one membrane, two valve springs and two head seals	1ED---0054
Sound absorber for 16694-2-50-22 and -1-60-22	1EH---0002
Sound absorber for 16694-2-50-06 and -1-60-06	1EH---0001
Fine adjustment head for 16694-2-50-22 and -1-60-22	1EV---0002
Fine adjustment head for 16694-2-50-06 and -1-60-06	1EV---0001
Fine adjustment head for 16694-2-50-06 and -1-60-06, for pressure filtration	1EV---0003



### Microsart® e.jet Transfer Pump with Quick Connection

The Microsart® e.jet is a new vacuum laboratory pump able to create sufficient vacuum for vacuum filtration and concomitantly transferring the filtered liquid directly to waste. The second generation of Microsart® e.jet is ideal for sample preparation in Microbiology achieving a trans membrane pressure of 600 mbar and a higher flow rate of > 4.0 NI/min (4.0 Normliters water displacement by air in one minute). Constant flow rates and a defined maximum vacuum guarantee smooth and reliable filtration.

### Reducing Operating Complexity

Until now vacuum equipment for the Membrane Filtration Method consists of numerous parts including connectors, tubes, vacuum containers, protection filter, Woulff's bottle and a vacuum pump. After several samples the vacuum must be broken to empty the filtrate collection container. The complete traditional equipment requires far more laboratory space and is time consuming to operate and maintain. Microsart® e.jet will eliminate the need for side-arm flasks or Woulff's bottles from the laboratory filtration bench.

The Microsart® e.jet pump is an ideal accessory for manifolds up to 3 filter stations. Compared to traditional equipment Microsart® e.jet and a stainless steel manifold require only 30% of the average space meaning in particular less congestion working in Laminar Flow Cabinets.

Traditional vacuum pumps often lose their efficiency and capability to generate sufficient vacuum, when liquid is drawn into the pump head. The Microsart® e.jet is designed to pump both gas and liquids, meaning no loss of efficiency or malfunctions from water drawn into the pump head.

### Quick Connection

Building-up the vacuum filtration system is easy and fast thanks to the innovative Quick Connections. The Microsart® e.jet Transfer Pump is equipped with Quick Connection Nipples assembled to Quick Connection Couplings on hose nipples for DN 10 tubings. Simply push-to-connect for assembling and pull-to-disassembling the whole system within seconds. The Quick Connections are non-shut-off.

Some of the advantages you will benefit from when using the Microsart® e.jet

- Ideal for microbiology applications
- No need of suction flasks and water traps
- Saving 70% of work space while saving money – that's economic efficiency

## ► Specifications

### Technical Specifications

Flow rate	> 4.0 NI/min
Max. Vacuum	0.4 bar
Max. Pressure	1.0 bar
Mains	100–240 V   47–63 Hz
Materials (in contact with filtrate)	PTFE, ETFE, Polypropylene, EPDM, POM, PSU
Weight	Pump: 1425.3 g Power supply: 242.6 g
Dimensions (W   L   H)	120 × 170 × 190 mm
Max. ambient Temp.	+5... +40°C
Max. Temp of liquid	+5... +80°C
Max. viscosity	< 150 cSt
Protection type	IP 64
Protection class	III
Inlet   Outlet	Quick Connection on hose nipples for DN 10 tubings

## Microsart® e.jet with Quick Connection

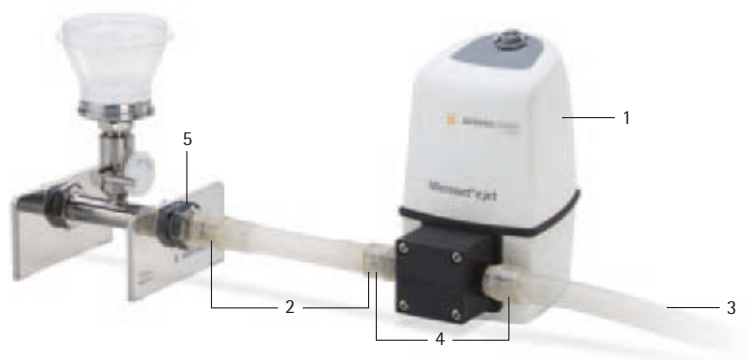

## Order Information

Description	Order Number	No. in picture
Microsart® e.jet Transfer Pump with Quick Connection, without tubings, inlet and outlet hose nipples for DN 10 tubings	166MP-4	1

Accessories	Order Number	No. in picture
Tubing with Quick Connection Coupling (PSU), silicone, 20 cm, for vacuum-sided connection, inner diameter DN 10, outer diameter DN 20, wall thickness 5 mm (when ordering, please state length required in meters)	1ZA---0006	2
Silicone tubing, 1 m, for pressure-sided connection, inner diameter DN 10, outer diameter DN 14, wall thickness 2 mm	1ZAS--0007	3
Foot switch for Microsart® e.jet Transfer Pump	1ZE---0053	

## Replacement Parts

Description	Order Number	No. in picture
Pump head complete for 166MP-3 and 166MP-4	1EP---0003	
Power supply complete for 166MP-3 and 166MP-4	1EE---0012	

## Threaded Fittings

Quick Connection set, 2 Nipples (POM) on R3/8" male thread and 2 Couplings (PSU) on DN 10 hose nipple	1EAS--0027	4
Quick Connection Nipple, stainless steel	1EAS--0026	5
DN 10 hose nipple on R3/8" male thread	1EAF--0020	



### Order Numbers Traditional Pumps

Description	Order No.
Multiple filtration runs: 13 mbar final vacuum, 26 l/min max., 220 V, 50 Hz	16612
Multiple filtration runs: 13 mbar final vacuum, 26 l/min max., 110 V, 60 Hz	16615
Individual filtration run: 100 mbar final vacuum, 20 l/min max., 220 V, 50 Hz	16692
Individual filtration run: 100 mbar final vacuum, 20 l/min max., 110 V, 60 Hz	16695



Replacement Parts	Order No.
Set of two neoprene membranes, four valve springs and two neoprene head seals for 16612/16615	6986017
Set of one neoprene membrane, two valve springs and one neoprene head seal for 16692/16695	6986105





**Water Jet Pump**

Simple vacuum source. For connection to a water tap with G3/4 male thread.

**Description**

Water jet pump, with G 3/4 female thread

**Order No.**

16611



**Hand-Operated Vacuum Pump**

Practical vacuum source, also outside of a laboratory. Up to 80% vacuum can be obtained. The body is of PVC. Supplied completely with gauge, vacuum release lever and a 60-cm length of clear plastic tubing.

**Description**

Hand-operated vacuum pump with gauge

**Order No.**

16673



**Dosing Syringe**

The most convenient way to moisten the NPS with water is to use a dosing syringe with an adapted Minisart® syringe filter. Simultaneous sterilization and dispensing of demineralized water in 3.5 ml steps is easily done by dropping the sinker at the end of the suction tubing into the water, then filling the dosing syringe and dispensing sterile water by operating the trigger automatically.

**Description**

Dosing syringe, 0.5–5 ml

**Order No.**

16685-----2

Minisart®, 0.2 µm, individually, sterile-packaged

17597-----K

Replacement part: tubing with sinker for 16685-2 and 16685

6986125

Service Kit for Dosing Syringe 16685-----2

1EP---0002



### Colony Counter

Compact, handy battery-operated colony counter, it is as simple to use as a ball-point pen, and has a 4-digit LCD-display. The counter is supplied with an additional marker refill.

#### Description

Colony counter

Replacement part: Black marker refill

#### Order No.

17649

6981540

### Incubator

Compact, space-saving incubator for the incubation of membrane filters on nutrient pads or other nutrient media. The incubator has a capacity of 18 liters and is designed to hold the following numbers and sizes of petri dishes: 200×47 mm or 160×56 mm | 60 mm or 72×90 mm.

The swing-up cover and removable insertion plate simplify loading and unloading. The cover is opaque, avoiding light penetration into the chamber.

## ▷ Specifications

### Incubator

18119

Voltage

100–240 V

Frequency

50 | 60 Hz

Rated power

0.045 kW

Weight

7.2 kg (15 lbs)

Max. shelf load

2 kg (4.4 lbs)

Dimensions W | H | D (mm)

Inner 290 | 180 | 310  
Outer 470 | 260 | 415

Temperature range

17°C to 40°C

Temperature stability at 37°C

Less than ±0.2°C

Temperature uniformity at 37°C

±1.2°C

Capacity

approx. 18 liters

#### Description

Incubator

#### Order No.

18119



#### Stainless Steel Tweezers

Membrane filters should only be handled with suitable tweezers to avoid contamination which can result from hand contact. Sartorius Stedim Biotech stainless steel tweezers can be flamed and they are autoclavable. They have blunt-edged tips for a careful, firm hold of the membrane filter.

#### Description

Stainless steel tweezers

#### Order No.

16625



#### Stainless Steel Prefilter Attachment

The stainless steel prefilter holder allows the removal of coarse, solid particles from samples for microbiological analysis before and during the actual bacteria retentive filtration. The device is clipped between funnel and base of the stainless steel vacuum filter holders. It can be autoclaved and flamed. 11301, a white cellulose nitrate (cellulose ester) membrane filter with a pore size of 8  $\mu\text{m}$  is used as the prefilter and it retains the coarse suspended particles from the sample, whereas it allows microorganisms to pass through. These microbes are trapped on the surface of the underlying bacteria-retentive membrane filter (e. g. 0.45  $\mu\text{m}$ ). After filtration is complete, the test filter is incubated, and the colonies can grow on the filter surface without disturbance from, or being hidden by, an excess of particles.

#### Description

Stainless steel prefilter attachment

#### Order No.

16807

Cellulose nitrate membranes with 50 mm diameter and 8  $\mu\text{m}$  pore size for the prefilter holder, pack of 100, individually, sterile packaged

11301--50----ACN

Replacement part: support plate, autoclavable, flammable

6981139



#### Container for Anaerobic Incubation

Stainless steel container with 11.8 cm inner diameter, 10.7 cm depth and a with metal insert for convenient insertion and removal of petri dishes. The plastic lid holds two taps for the vacuum exhaust and for cleaning with inert gas, with 6 mm hose nipples (for 16623), vacuum gauge and sealing ring. For up to fourteen 60 mm, or up to six 90 mm petri dishes.

#### Description

Anaerobic container

#### Order No.

16671

## ► Sterility Testing Systems Sterisart® Universal Pump



International pharmacopeias require the complete sterility of pharmaceutical products that are injected into the blood stream or that otherwise enter the body below the skin surface. Manufacturer of such products are required to supply proof of sterility of the final product batch.

The Sterisart® Universal Pump is available in two versions: the basic version 16419 and the upgraded version 16420 with display and user software. The pump can be used in clean rooms, integrated into clean benches, or installed countersunk in the working surface of isolators. Its low, compact design has a space-saving footprint – a great benefit for most clean room benchtops and isolators.

### **Additional Features and Benefits**

- Enhanced safety due to the closed system without ventilation
- Robust stainless steel housing
- Compact and ergonomic construction
- Modular design
- Pump available with special software (menu-driven prompts for operator guidance; all process sequences can be logged; barcode recognition)

Special brochures available on request.  
Order no. SLD1003-e, SLD2010

## ▷ Specifications

### Technical Specifications for Sterisart® Universal Pump

Pump flow rate	70–650 ml/min
Power requirements	100–240 VAC
Frequency	50–60 Hz
Power consumption	100 W
Dimensions	
Pump	approx. 336×260×210 mm (with lever) (W×D×H)
Pump with holding ring for bottles, container	approx. 440×365×485 mm (W×D×H)
Weight	
Basic version 16419	approx. 13.5 kg
Upgraded version 16420 with display and user software	approx. 14.6 kg

### Ordering Information

Order No.	Description
16419	Sterisart® Universal pump, basic version
16420	Sterisart® Universal pump, upgraded version with display and user software

### Accessories

Order Number	Description
1ZE---0033	Footswitch
1ZG---0014	Adapter for Sterisart® NF units, fitting into container for draining of Millipore Equinox pump
1ZE---0039	Transport trolley
1ZE---0040	Communication kit
1ZE---0050	Installation kit for isolators

Further accessories are available on request.

## ► Sterility Testing Systems Sterisart® NF



Sterisart® NF is a completely closed system for the sterility testing of pharmaceutical products. It is based on the membrane filter method, however it eliminates the procedure of manipulating the filters. By this means the main risk of a secondary contamination and false positive results is eliminated. A peristaltic pump transfers the sample into the filtration units. After rinsing, the filtration units are filled with media and used for incubation of the filters without any contact to the environment.



As different pharmaceutical products and their containers need different systems for a convenient and secure sample transfer different versions adapted to the needs are available. Detailed information can be found in the corresponding data sheets Order no. SLD1002-e, SL-2019-e, SLD2006-e, SLD2005-e, SLD2007-e, S--2019-e, SLD2009-e, SLD2011-e

### **Sterisart® NF Offers the Following Features and Benefits**

Ergonomical and safe handling

- Easy to open packaging
- Large color-coded clamps for optimized use with gloves
- Protective shields to avoid injuries

Reliable results

- Sartochem® membrane for high retention of microbes, low adsorption and high mechanical stability
- Gas-impermeable packaging for use in isolators
- Product and lot information on units and additionally as barcode on packaging

Flexible use

- Different variants with several user friendly adapters for the most common sample containers
- Septum variants for sampling during incubation

## ▷ Specifications

### Technical Specifications for Sterisart® NF

Pore size of the Sartochem® membrane filter	0.45 µm, tested with <i>Serratia marcescens</i>
Filter area	15.7 cm <sup>2</sup> in each Sterisart® container
Flow rate (for water)	500 ml/min at 1 bar (approx. 15 psi)
Pore size of the air filters	0.2 µm PTFE, validated acc. to HIMA for the retention of <i>B. diminuta</i>
Sample container capacity	120 ml (graduation marks at 50, 75 and 100 ml)
Max. operating pressure	3 bar (approx. 44 psi) at 20°C
Max. operating temperature	50°C
Sterilization	ETO (ethylene oxid gas) or gamma irradiation

### Ordering Information

#### Sterisart® NF alpha Disposable Units for Sterility Testing in Clean Rooms, Individually, Sterile Packaged, ETO-Sterilized, Needles Made of Flame-Sterilizable Stainless Steel, 10 Units

Type of Sample	Type of Sample Container	Description	Order No.
LVPs	Closed glass bottles with septum	Sterisart® NF alpha with long dual-needle metal spike, sterile-vented	16466-----ACD
LVPs SVPs	Open containers (i.e. glass ampoules, glass bottles), collapsible bags	Sterisart® NF alpha with long needle and protective plate, inclusive sterile venting needle	16467-----ACD
Medical devices	Tubing systems and bags with Luer or Luer Lock connectors	Sterisart® NF alpha with Luer or Luer Lock connector, inclusive long needle and sterile venting needle	16468-----ACD

**Sterisart® NF gamma Disposable Units for Sterility Testing in Isolators, Individually Sterile, Double-Packaged, Gamma Irradiated, Needles Made of Flame-Sterilizable Stainless Steel, 10 Units**

Type of Sample	Type of Sample Container	Description	Order No.
LVPs	Closed glass bottles with septum	Sterisart® NF gamma with long dual-needle metal spike, sterile-vented	16466-----GBD
SVPs	Closed glass vials with septum	Sterisart® NF gamma with short dual-needle metal spike, sterile-vented	16476-----GBD
LVPs, SVPs, eye drops	Closed plastic containers   vials   ampoules, plastic containers of Blow-Fill-Seal fillings	Sterisart® NF gamma with long needle (side side opening, with solid pointed tip, non-coring), protective plate, inclusive sterile venting needle	16477-----GBD
LVPs SVPs	Open containers (i.e. glass ampoules, glass bottles), collapsible bags	Sterisart® NF gamma with long needle and protective plate, inclusive sterile venting needle	16467-----GBD
Lyophilisates, soluble powders, liquid antibiotics	Closed glass vials with septum	Sterisart® NF gamma with two dual-needle metal spikes of different length, one is sterile-vented	16475-----GBD
Pre-filled syringes	Syringes with and without needles	Sterisart® NF gamma with syringe-adapter and long dual-needle metal spike, sterile-vented	16469-----GBD
Medical devices	Tubing systems and bags with Luer or Luer Lock connectors	Sterisart® NF gamma with Luer or Luer Lock connection, inclusive long needle and sterile venting needle	16468-----GBD
<b>NEW</b> Medical devices	Containers   bags with Luer Lock male connectors	Sterisart® NF gamma with female Luer Lock connector	16478-----GBD



**Sterisart® NF gamma Septum, Disposable Units for Sterility Testing in Isolators, Sterisart® NF Containers with Integrated Septum for Reliable Sterile Sampling During Incubation Individually Sterilized, Double-Packaged, Gamma Irradiated, Needles Made of Flame-Sterilizable Stainless Steel, 10 Units**

LVPs	Closed glass bottles with septum	Sterisart® NF gamma Septum with long dual-needle metal spike, sterile-vented	16466-----GSD
LVPs SVPs	Open containers (i.e. glass ampoules, glass bottles), collapsible bags	Sterisart® NF gamma Septum with long needle and protective plate, inclusive sterile venting needle	16467-----GSD
Lyophilisates, Soluble powders, Liquid antibiotics	Closed glass vials with septum	Sterisart® NF gamma Septum with two dual-needle spikes of different length, one is sterile-vented	16475-----GSD
Pre-filled syringes	Syringes with and without needles	Sterisart® NF gamma Septum with syringe-adapter and long dual-needle metal spike, sterile-vented	16469-----GSD

**Accessories**

<b>Application</b>	<b>Description</b>	<b>Order No.</b>
Dissolving and diluting of hardly soluble powders in closed containers	Sterisart® NF gamma tubing system with two dual-needle metal spikes of different length, needles made of flammable stainless steel	16470-----GBD
Sterile venting of containers with rinsing solution and nutrient media, additional sterile venting needles, equal to the included needles of the Sterisart® NF units, i.e. type 16467, 16468 and 16477	Needle with venting filter, 4 cm, stainless steel, individually sterile packaged, gamma-irradiated, pack size 50	16596-----HMK

Further units on request.

## ► Reusable Sterility Test System



Reusable sterility test system for the sterility testing of injection and infusion solutions. The filter holders are easy to clean, dishwasher-safe and autoclavable. The system can be designed according to the needs of the user, and the membrane filter can be chosen according to requirements.

### ▷ Specifications

#### Specifications of the Filter Holders

Material	Glass cylinder; polypropylene base and sealing plug; anodized aluminum closing cap.
Sealing	Silicone gasket, 36/47 mm (6980573) Silicone O-ring, 40.5×3.5 mm (6980574)
Filter diameter	47 mm
Filtration area	12.5 cm <sup>2</sup>
Capacity	16523: 130 ml (56 ml up to the mark for aerobic incubation at a level of 60 mm, 110 ml up to the mark at the 115-mm level).
Operating pressure	Vacuum only
Sterilization	Autoclaving at 121 °C

#### General Accessories for the Reusable Sterility Test System

Description	Order Numbers
Filter holder with 130 ml capacity	16523
Stainless steel manifold	16826
Stainless-steel adapter	17756
T-distributor for 2 filter holders	16966
Filling cap with filling needle	16967
Silicone adapter	16968
Peristaltic pump	16696
Silicone tubing, 4×1.5 mm	16699
Holding rod for inlet tube   needle	16974
Incubation rack	16975
Tube clamps (tubing clips)	16978
Venting filters, pack size 50	17574-----K

#### Additional Accessories for Reusable Sterility Test System (for Ampoule Testing)

Description	Order Numbers
Inlet tube	16963
Holding tongs	16973
Ampoule breaker	16969
Clamp holder	16976
Support stand	16970

### Additional Accessories for Reusable Sterility Testing System (for Testing Infusion Solutions in Bottles)

Description	Order Numbers
Inlet needle (long)	16964
Inlet needle (short)	16964-----3

### Consumables (Membrane Filters, 47 mm, 100 Pieces/pack) for the Reusable Sterility Test System

Order Numbers	Pore Size	Description	Application
11306--47-----N	0.45 µm	Cellulose nitrate membrane filter	pH 4-8, most hydrocarbons
13106--47----HCN	0.45 µm	Cellulose nitrate membrane filter with hydrophobic edge	pH 4-8, most hydrocarbons
11106--47-----N	0.45 µm	Cellulose acetate membrane filter	pH 4-8, most alcohols, hydrocarbons and oils
13506--47----HCN	0.45 µm	Cellulose acetate membrane filter with hydrophobic edge	pH 4-8, most alcohols, hydrocarbons and oils
18406--47-----N	0.45 µm	Regenerated cellulose membrane filter	pH 3-12, solvent-resistant
11407--47-----N	0.2 µm	Cellulose nitrate membrane filter	pH 4-8, most hydrocarbons
13107--47----HCN	0.2 µm	Cellulose nitrate membrane filter with hydrophobic edge	pH 4-8, most hydrocarbons
11107--47-----N	0.2 µm	Cellulose acetate membrane filter	pH 4-8, most alcohols, hydrocarbons and oils
13507--47----HCN	0.2 µm	Cellulose acetate membrane filter with hydrophobic edge	pH 4-8, most alcohols, hydrocarbons and oils
18407--47-----N	0.2 µm	Regenerated cellulose membrane filter	pH 3-12, solvent-resistant



### Peristaltic Pump

#### Specifications

Rotor speed	1.5–220 rpm
Operating voltages and frequencies	110–240 V 50/60 Hz
Speed control ratio	147:1
Power rating	100 VA
Operating temperature	4°C to 40°C
Storage temperature range	–40°C to 70°C
Weight	5.5 kg   12.1 lbs
Noise	<70 dBA at 1 m
Standards	IEC 335-1, EN 60529 (IP31)
Machinery Directive	98/37/EG EN 60204-1
Low Voltage Directive	73/23/EG EN 61010-1
EMC Directive	89/336/EG EN 50081-1/EN 50082-1

#### Order Number

16696

# Index

- Absorbent Pads 26
- Accessories for vacuum filter holders and manifold systems 50
- Airborne bacteria and viruses 8
- Air Monitoring 4
- AirPort MD8 5, 8
- Air Sampler 4, 7
- Aluminum stack 8
  
- BACTair™ 7
- Biosart® 100 Monitor 28, 29, 41
- Biosart® 100 Nutrient media 30
- Biosart® 250 Funnel 36, 37
  
- Calibration Unit 8
- Case for MD8 airscan® 9
- Cellulose acetate 11, 18, 20, 67
- Cellulose Nitrate (Cellulose Ester) 10, 14, 16, 18, 20, 59
- Colony Counter 58
- Colony Counting 10
- Combisart® multi-branch systems 38
- Container for anaerobic incubation 59
- Culture media 7, 22, 26, 30
  
- Dispenser 12, 27
- Dosing syringe 57
  
- Filter dispenser 12
- Filter holders and manifolds 38
- Filter holders, individual 47
  
- Gelatine membrane filters 6
- Gridded membrane filters for colony counting 10
- Gridded membrane filters, type 111 19
- Gridded membrane filters, type 113 19
- Gridded membrane filters, type 114 15, 17
- Gridded membrane filters, type 130 15, 17
- Gridded membrane filters, type 131 21
- Gridded membrane filters, type 135 21
- Gridded membrane filters, type 138 15, 17
- Gridded membrane filters, type 139 15, 17
  
- Hand-operated vacuum pump with gauge 57
- High flow membranes 11, 28
  
- Laboratory pump, 90% 56
- Laboratory pump, 98% 56
  
- Manifolds, multi-branch 47
- MD8 airscan® 4, 6, 8, 9
- MD8 Calibration Unit 8
- MD8 devices 8
- Media 22
- Microsart® @filter 100 and 250 32
- Microsart® @vance® 32
- Microsart® Combi.jet 42
- Microsart® e.jet 46, 54, 55
- Microsart® e.motion 12, 25
- Microsart® e.motion Dispenser 12
- Microsart® e.motion 12, 25
- Membrane Filters 13, 25
- Microsart® Funnel 100 and 250 34
- Microsart® maxi.vac 52, 53
- Microsart® mini.vac 45, 52, 53
- Minisart® SRP 41
- Multi-branch manifolds, traditional 47
  
- NPS 22, 57
- Nutrient media broth 30
- Nutrient pad sets in petri dishes 22
  
- Peristaltic pump 67
- Preassembled Monitors 28
  
- Quick Connection for Tubings 43, 55
  
- Ready-to-use units including media 28
- Reusable sterility test system 66
- Rubber vacuum hose 51
  
- Sartochem® 63
- Single-use funnels 36
- Stainless steel filter holder, 50 mm, with vacuum control 47
- Stainless steel funnels 38, 39
- Sterility Testing Systems 60
- Sterisart® NF 62, 63
- Sterisart® Universal Pump 60
- Suction flask, 2 liter capacity 50
  
- Vacusart® 45, 50, 51
- Vacuum filtration system 44
  
- Water jet pump 57
- Water trap, Vacusart® 51
- Woulff's bottle 51







# Sales and Service Contacts

For further contacts, visit [www.sartorius-stedim.com](http://www.sartorius-stedim.com)

## Europe

### Germany

Sartorius Stedim Biotech GmbH  
August-Spindler-Strasse 11  
37079 Goettingen

Phone +49.551.308.0  
Fax +49.551.308.3289

[www.sartorius-stedim.com](http://www.sartorius-stedim.com)

Sartorius Stedim Systems GmbH  
Robert-Bosch-Strasse 5-7  
34302 Guxhagen

Phone +49.5665.407.0  
Fax +49.5665.407.2200

### France

Sartorius Stedim Biotech S.A.  
ZI Les Paluds  
Avenue de Jouques - BP 1051  
13781 Aubagne Cedex

Phone +33.442.845600  
Fax +33.442.845619

Sartorius Stedim France SAS  
ZI Les Paluds  
Avenue de Jouques - CS 71058  
13781 Aubagne Cedex

Phone +33.442.845600  
Fax +33.442.846545

### Austria

Sartorius Stedim Austria GmbH  
Franzosengraben 12  
A-1030 Vienna

Phone +43.1.7965763.18  
Fax +43.1.796576344

### Belgium

Sartorius Stedim Belgium N.V.  
Leuvensesteenweg, 248/B  
1800 Vilvoorde

Phone +32.2.756.06.80  
Fax +32.2.756.06.81

### Denmark

Sartorius Stedim Nordic A/S  
Hoerskaetten 6D, 1.  
DK-2630 Taastrup

Phone +45.7023.4400  
Fax +45.4630.4030

### Hungary

Sartorius Stedim Hungária Kft  
Kagyló u. 5  
2092 Budakeszi

Phone +36.23.457.227  
Fax +36.23.457.147

### Italy

Sartorius Stedim Italy S.p.A.  
Via dell'Antella, 76/A  
50012 Antella-Bagno a Ripoli (FI)

Phone +39.055.63.40.41  
Fax +39.055.63.40.526

### Netherlands

Sartorius Stedim Netherlands B.V.  
Edisonbaan 24  
3439 MN Nieuwegein

Phone +31.30.6025080  
Fax +31.30.6025099

### Poland

Sartorius Stedim Poland Sp. z o.o.  
ul. Wrzesinska 70  
62-025 Kostrzyn

Phone +48.61.647.38.40  
Fax +48.61.879.25.04

### Russian Federation

000 "Sartorius ICR"  
Rasstannaya str. 2, b.2, lit.A, p/b 134  
192007, Saint-Petersburg

Phone +7.812.6100821  
Fax +7.812.6100821

### Spain

Sartorius Stedim Spain SA  
C/Isabel Colbrand 10,  
Oficina 70  
Poligono Industrial de Fuencarral  
28050 Madrid

Phone +34.90.2110935  
Fax +34.91.3589623

### Switzerland

Sartorius Stedim Switzerland AG  
Ringstr. 24 a  
8317 Tagelswangen

Phone +41.52.354.36.36  
Fax +41.52.354.36.46

### U.K.

Sartorius Stedim UK Limited  
Longmead Business Park  
Blenheim Road, Epsom  
Surrey KT19 9 QQ

Phone +44.1372.737159  
Fax +44.1372.726171

## America

### USA

Sartorius Stedim North America Inc.  
5 Orville Drive  
Bohemia, NY 11716

Toll-Free +1.800.368.7178  
Fax +1.631.254.4253

Sartorius Stedim SUS Inc.  
1910 Mark Court  
Concord, CA 94520

Phone +1.925.689.6650  
Toll Free +1.800.914.6644  
Fax +1.925.689.6988

### Argentina

Sartorius Argentina S.A.  
Int. A. Avalos 4251  
B1605ECS Munro  
Buenos Aires

Phone +54.11.4721.0505  
Fax +54.11.4762.2333

### Brazil

Sartorius do Brasil Ltda  
Av. Dom Pedro I, 241  
Bairro Vila Pires  
Santo André  
São Paulo  
Cep 09110-001

Phone +55.11.4451.6226  
Fax +55.11.4451.4369

### Mexico

Sartorius de México S.A. de C.V.  
Circuito Circunvalación Poniente No. 149  
Ciudad Satélite  
53100 Naucalpan, Estado de México

Phone +52.5555.62.1102  
Fax +52.5555.62.2942

## Asia | Pacific

### Australia

Sartorius Stedim Australia Pty. Ltd.  
Unit 5, 7-11 Rodeo Drive  
Dandenong South Vic 3175

Phone +61.3.8762.1800  
Fax +61.3.8762.1828

### China

Sartorius Stedim Beijing  
Representative Office  
No. 33, Yu'an Road,  
Airport Industrial Zone B, Shunyi District  
Beijing 101300

Phone +86.10.80426516  
Fax +86.10.80426580

Sartorius Stedim Shanghai

Representative Office  
Room 618, Tower 1, German Centre,  
Shanghai, PRC., 201203

Phone +86.21.28986393  
Fax +86.21.28986392.11

Sartorius Stedim Guangzhou Office  
Room 704, Broadway Plaza,  
No. 233-234 Dong Feng West Road  
Guangzhou 510180

Phone +86.20.8351.7921  
Fax +86.20.8351.7931

### India

Sartorius Stedim India Pvt. Ltd.  
#69/2-69/3, Jakkasandra  
Kunigal Road, Nelamangala Tq  
Bangalore - 562 123

Phone +91.80.4350.5361  
Fax +91.80.4350.5253

### Japan

Sartorius Stedim Japan K.K.  
KY Building, 8-11  
Kita Shinagawa 1-chome  
Shinagawa-ku  
Tokyo 140-0001

Phone +81.3.3740.5407  
Fax +81.3.3740.5406

### Malaysia

Sartorius Stedim Malaysia Sdn. Bhd.  
Lot L3-E-3B, Enterprise 4  
Technology Park Malaysia  
Bukit Jalil  
57000 Kuala Lumpur

Phone +60.3.8996.0622  
Fax +60.3.8996.0755

### Singapore

Sartorius Stedim Singapore Pte. Ltd.  
1 Science Park Road,  
The Capricorn, #05-08A,  
Singapore Science Park 2  
Singapore 117528

Phone +65.6872.3966  
Fax +65.6778.2494

### South Korea

Sartorius Korea Biotech Co., Ltd.  
8th Floor, Solid Space B/D,  
PanGyoYeok-Ro 220, Bundang-Gu  
SeongNam-Si, GyeongGi-Do, 463-400

Phone +82.31.622.5700  
Fax +82.31.622.5799



◀ [www.sartorius-stedim.com](http://www.sartorius-stedim.com)